

# DESPIECE SPAREPARTS

**MOTORES DIESEL:  
D400 / D450 / D500**

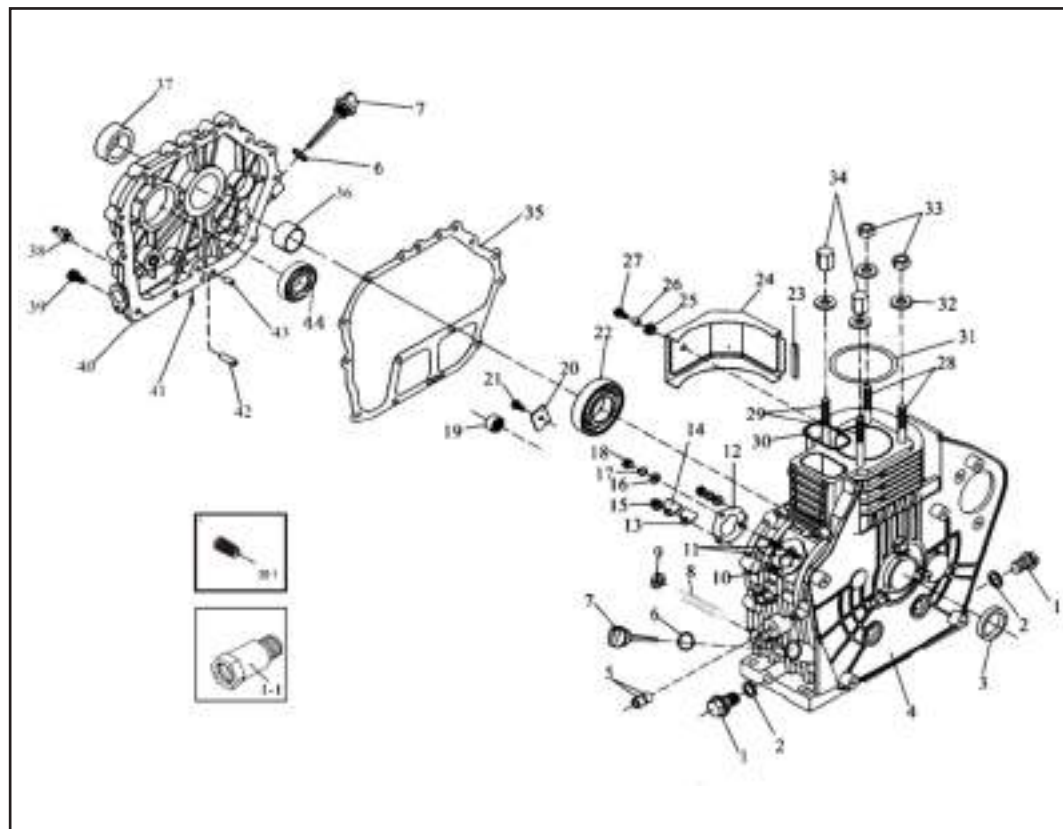

Nº	REF.	DESCRIPCIÓN (ES)	DESCRIPTION (EN)
1	SP-D400-A01	TORNILLO DE DRENAJE M16X16X1,5	DRAIN PLUG SCREW M16X16X15.5
1-1	SP-D400-A01-1	PROLONGADOR DEL TORNILLO DE DRENAJE	CONNECTING BOLT OF DRAIN PLUG
2	SP-D400-A02	ARANDELA TORNILLO DRENAJE Ø16,5	WASHER UNIT OF DRAIN PLUG Ø16.5
3	SP-D400-A03	SELLO DE ACEITE REAL Ø35XØ50X8	REAL OIL SEAL Ø35×Ø50×8
4	SP-D400-A04	BLOQUE DE MOTOR/CARTER	ENGINE BLOCK / CRANKCASE
4-1	SP-D450-A04-1	BLOQUE DE MOTOR/CARTER	ENGINE BLOCK / CRANKCASE
4-2	SP-D450-A04-2	BLOQUE DEL CILINDRO	CYLINDER BLOCK
4-3	SP-D450-A04-3	JUNTA DEL BLOQUE DE CILINDRO	CYLINDER BLOCK GASKET
4-4	SP-D500-A04-4	BLOQUE DE MOTOR/CARTER	ENGINE BLOCK / CRANKCASE
5	SP-D400-A05	COJINETE DE AGUJAS HK081410	NEEDLE BEARING HK081410
6	SP-D400-A06	JUNTA Ø24X2,4	O-RING Ø24×2.4
7	SP-D400-A07	VARILLA DE ACEITE	OIL DIPSTICK
8	SP-D400-A08	CONJUNTO TOPE ACELERADOR	THROTTLE STOP ASSEMBLY
9	SP-D400-A09	TUERCA M10X1,25	NUT M10×1.25
10	SP-D400-A10	PERNO(CORTO) AM6X30	BOLT (SHORT) AM6×30
11	SP-D400-A11	PERNO(LARGO) AM6X36	BOLT (LONG) AM6×36
12	SP-D400-A12	JUNTA BOMBA COMBUSTIBLE 0,1~0.5MM	FUEL INJECTION PUMP WASHER 0.1~0.5MM
13	SP-D400-A13	JUNTA BOMBA	JOINT WASHER
14	SP-D400-A14	PLACA DE SELLO	SEAL PLATE
15	SP-D400-A15	TUERCA M6	NUT M6
16	SP-D400-A16	Ø6 ARANDELA PLANA	FLAT WASHER Ø6
17	SP-D400-A17	Ø6 ARANDELA ELÁSTICA	SPRING WASHER Ø6
18	SP-D400-A18	TUERCA M6	NUT M6
19	SP-D400-A19	IKO COJINETE DE AGUJA TIA1512Z	IKO NEEDLE BEARING TIA1512Z
20	SP-D400-A20	PLACA FIJACION	THRUST PLATE
21	SP-D400-A21	PERNO BRIDA M8X12	FLANGE BOLT M8×12
22	SP-D400-A22	COJINETE DE BOLAS 6308	BALL BEARING 6308
23	SP-D400-A23	AMORTIGUADOR DE CHOQUE	CUSHION SHOCK ABSORBER
24	SP-D400-A24	DEFLECTOR DEL CILINDRO	CYLINDER BAFFLE
25	SP-D400-A25	AMORTIGUADOR DE VIBRACIONES	VIBRATION ISOLATION CUSHION BLOCK
26	SP-D400-A26	VAINA	SHEATH
27	SP-D400-A27	TORNILLO DE BRIDA M6X18	FLANGE BOLT M6×18
28	SP-D400-A28	TORNILLO DEL CILINDRO AM10X1.5X108	CYLINDER HEAD STUD BOLT(SHORT) AM10×1.5×108
28-1	SP-D450-A28-1	TORNILLO DEL CILINDRO AM10X1.5X190	CLYLINDER HEAD STUD BOLT (SHORT) AM10X1.5X190
28-2	SP-D500-A28-2	TORNILLO DEL CILINDRO AM12X1.5X108	CYLINDER HEAD STUD BOLT (SHORT) AM12X1.5X108
29	SP-D400-A29	TORNILLO DEL CILINDRO AM10X1.5X122	CYLINDER HEAD STUD BOLT(LONG) AM10×1.5×122
29-1	SP-D450-A29-1	TORNILLO DEL CILINDRO AM10X1.5X204	CYLINDER HEAD STUD BOLT (LONG) AM10X1.5X204



FAST MOVING PARTS

RECOMMENDED PARTS

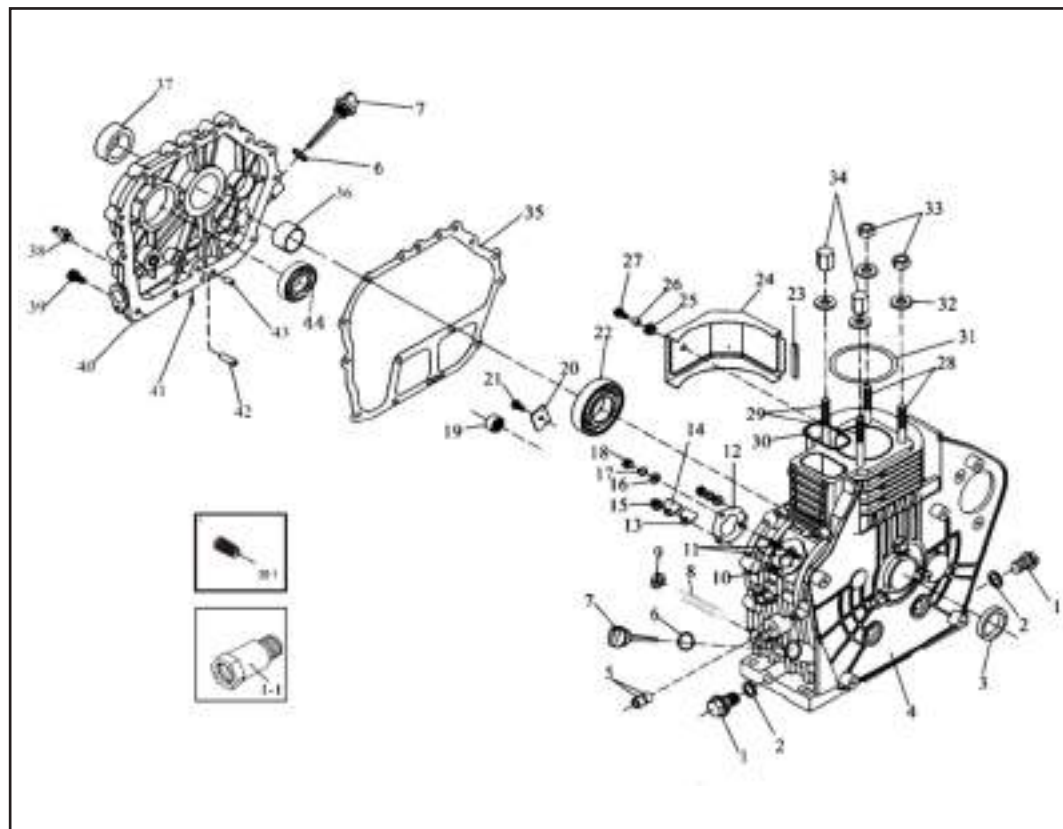

Nº	REF.	DESCRIPCIÓN (ES)	DESCRIPTION (EN)
29-2	SP-D500-A29-2	TORNILLO DEL CILINDRO AM12X1.5X121	CYLINDER HEAD STUD BOLT (LONG) AM12X1.5X121
30	SP-D400-A30	JUNTA CULATA GOMA RECTANGULAR 5.1X2.3	RECTANGLE RING 5.1x2.3
31	SP-D400-A31	JUNTA CULATA COBRE 0.1~0.5MM	CYLINDER HEAD SHIM (0.1~0.5MM)
31-1	SP-D450-A31-1	JUNTA CULATA COBRE 0.1~0.5MM	CYLINDER HEAD SHIM (0.1~0.5MM)
31-2	SP-D500-A31-2	JUNTA CULATA COBRE 0.3MM	CYLINDER HEAD SHIM (0.3MM)
32	SP-D400-A32	ARANDELA DE LA CULATA Ø10.5	CYLINDER HEAD NUT GASKET Ø10.5
32-1	SP-D500-A32-1	ARANDELA DE LA CULATA Ø10.5	CYLINDER HEAD NUT GASKET Ø10.5
33	SP-D400-A33	TUERCA DE LA CULATA (CORTA)	CYLINDER HEAD NUT(SHORT)
33-1	SP-D500-A33-1	TUERCA DE LA CULATA (CORTA)	CYLINDER HEAD NUT(SHORT)
34	SP-D400-A34	TUERCA DE LA CULATA (LARGA)	CYLINDER HEAD NUT(LONG)
34-1	SP-D500-A34-1	TUERCA DE LA CULATA (LARGA)	CYLINDER HEAD NUT(LONG)
35	SP-D400-A35	JUNTA BLOQUE MOTOR	CRANKCASE COVER WASHER
36	SP-D400-A36	CASQUILLO PRINCIPAL	MAIN BUSH
37	SP-D400-A37	RETEN FRONTAL DE ACEITE Ø35XØ50X10	FRONT OIL SEAL Ø35xØ50x10
38	SP-D400-A38	SENSOR PRESIÓN DE ACEITE	LOW OIL ALARM
38-1	SP-D400-A38-1	TAPÓN ROSCADO HEXAGONAL INTERNO	HEXAGONAL INTERNAL SCREW PLUG
39	SP-D400-A39	REMACHE M8X33,5	BOLT M8x33.5
40	SP-D400-A40	TAPA BLOQUE MOTOR	CRANKCASE COVER
40-1	SP-D400-A40-1	TAPA BLOQUE MOTOR CON DESCOMPRESOR	CRANKCASE COVER WITH DECOMPRESSOR
40-2	SP-D500-A40-2	TAPA BLOQUE MOTOR CON DESCOMPRESOR	CRANKCASE COVER WITH DECOMPRESSOR
41	SP-D400-A41	REMACHE 8X8	PLUNGER 8x8
42	SP-D400-A42	CONDUCTO DE ACEITE	OIL CONDUIT
43	SP-D400-A43	PIN 8X12	PIN 8x12
44	SP-D400-A44	COJINETE DE BOLAS 6207	BALL BEARING 6207



FAST MOVING PARTS

RECOMMENDED PARTS

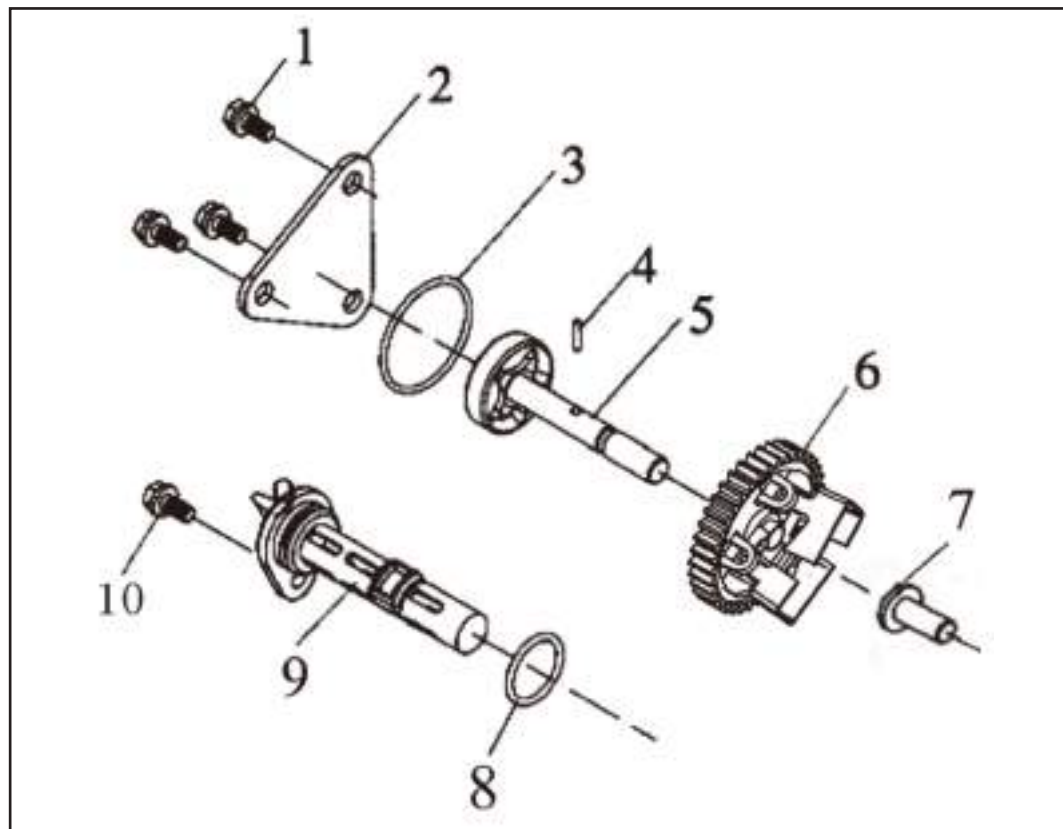

Nº	REF.	DESCRIPCIÓN (ES)	DESCRIPTION (EN)
1	SP-D400-B01	TORNILLO M6X12	BOLT M6×12
2	SP-D400-B02	TAPA BOMBA DE ACEITE	LUBE OIL PUMP COVER
3	SP-D400-B03	JUNTA TORICA Ø34.5X1.8	O-RING Ø34.5×1.8
4	SP-D400-B04	PIN 3X16	PIN 3×16
5	SP-D400-B05	UNIDAD DE LA BOMBA DE ACEITE DEL MOTOR	ENGINE OIL PUMP UNIT
6	SP-D400-B06	GOVERNADOR DE LA BOMBA DE ACEITE	DRIVE GEAR OF LUBE OIL PUMP
7	SP-D400-B07	TETON DE EMPUJE DEL REGULADOR	GOVERNOR PUSH REEL
8	SP-D400-B08	JUNTA TORICA Ø20X2,52	O-RING Ø20×2.52
9	SP-D400-B09	CONJUNTO DEL FILTRO DE ACEITE	LUBE OIL FILTER ASSY
10	SP-D400-B10	TORNILLO M6X14	BOLT M6×14



SP-D400-B05

SP-D400-B06

SP-D400-B07

SP-D400-B09

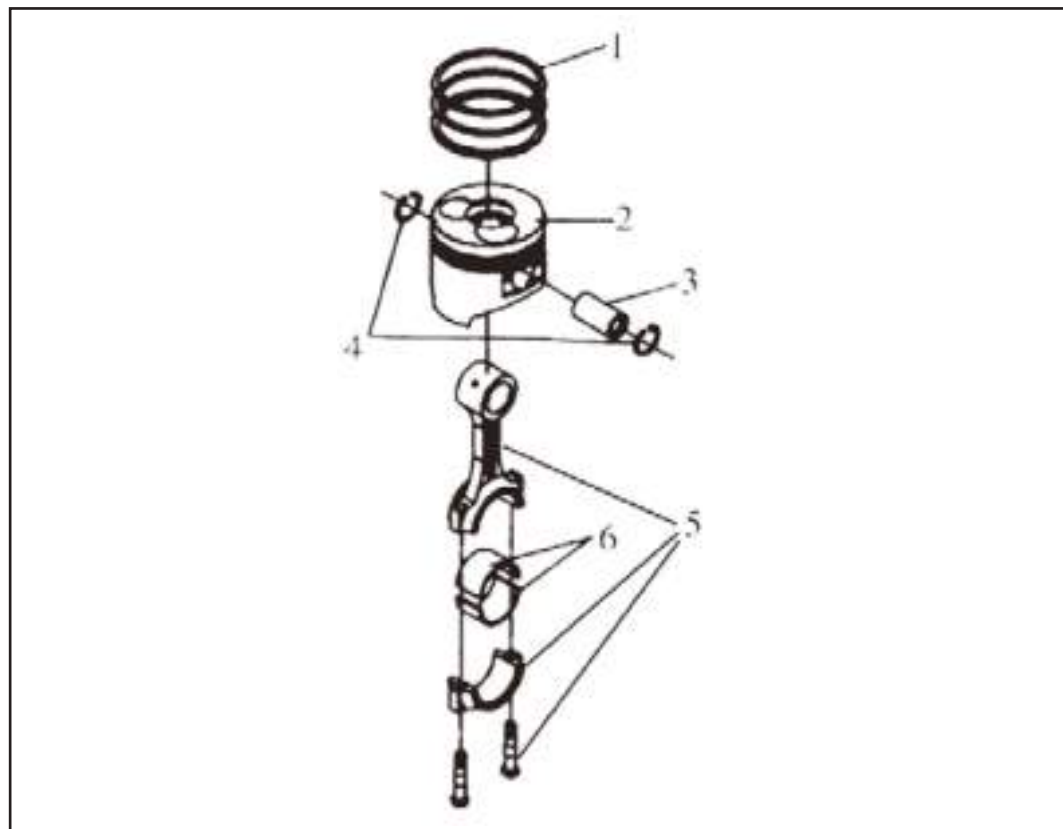

Nº	REF.	DESCRIPCIÓN (ES)	DESCRIPTION (EN)
1	SP-D400-C01	JUEGO SEGMENTOS	PISTON RING SET
1-1	SP-D450-C01-1	JUEGO SEGMENTOS	PISTON RING SET
1-2	SP-D500-C01-2	JUEGO SEGMENTOS	PISTON RING SET
2	SP-D400-C02	PISTON	PISTON
2-1	SP-D450-C02-1	PISTON	PISTON
2-2	SP-D500-C02-2	PISTON	PISTON
2-3	SP-D400-C02-NO FA	PISTON NO FA	PISTON NO FA
3	SP-D400-C03	BURLON DEL PISTON	PISTON PIN
3-1	SP-D450-C03-1	BURLON DEL PISTON	PISTON PIN
3-2	SP-D500-C03-2	BURLON DEL PISTON	PISTON PIN
4	SP-D400-C04	CLIP DEL BULON DEL PISTON	PISTON PIN CLIP
5	SP-D400-C05	CONJUNTO BIELA	CONNECTING ROD ASSY
5-1	SP-D450-C05-1	CONJUNTO BIELA	CONNECTING ROD ASSY
5-2	SP-D500-C05-2	CONJUNTO BIELA	CONNECTING ROD ASSY
6	SP-D400-C06	CASQUILLOS BIELA (JUEGO)	CONNECTING ROD BUSH (SET)
6-1	SP-D500-C06-1	CASQUILLOS BIELA (JUEGO)	CONNECTING ROD BUSH (SET)



SP-D450-C01-1



SP-D450-C02-1



SP-D450-C03-1



SP-D450-C05-1

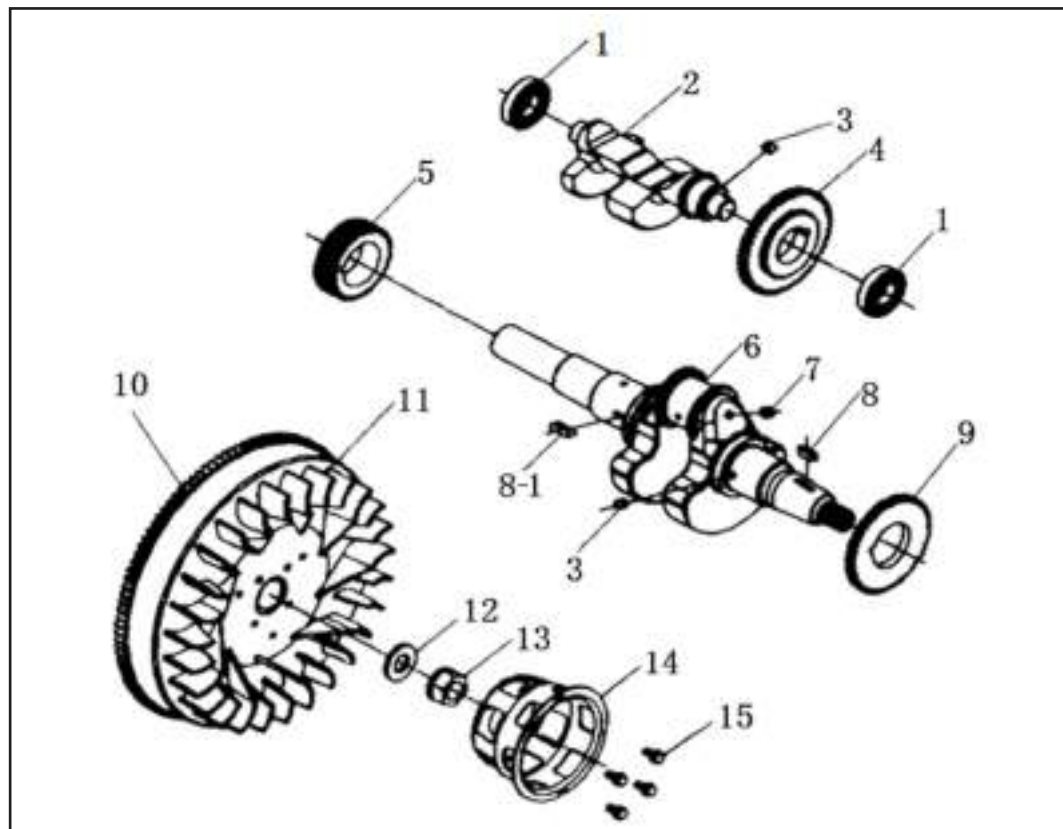

Nº	REF.	DESCRIPCIÓN (ES)	DESCRIPTION (EN)
1	SP-D400-D01	COJINETE DE BOLAS 6203	BALL BEARING 6203
2	SP-D400-D02	EJE DE BALANCE	BALANCE SHAFT
3	SP-D400-D03	CHAVETA 5X7	KEY 5x7
4	SP-D400-D04	PIÑÓN EJE BALANCINES	TIMING GEAR OF BALANCE SHAFT
5	SP-D400-D05	PIÑÓN CIGÜEÑAL	CRANKSHAFT TIMING GEAR
6	SP-D400-D06	CIGÜEÑAL	CRANKSHAFT
6-1	SP-D450-D06-1	CIGÜEÑAL	CRANKSHAFT
6-2	SP-D500-D06-2	CIGÜEÑAL	CRANKSHAFT
7	SP-D400-D07	REMACHE DE ACERO Ø6.35	STEEL BALL Ø6.35
8	SP-D400-D08	CHAVETA 5x14mm	KEY 5x14mm
8-1	SP-D400-D08-1	CHAVETA 5x11,5mm	KEY 5x11,5mm
9	SP-D400-D09	PIÑÓN CIGÜEÑAL BALANCINES	DRIVE GEAR OF BALANCE SHAFT
10	SP-D400-D10	CORONA DENTADA	FLYWHEEL RING GEAR
11	SP-D400-D11	VOLANTE DE INERCIA COMPLETO	FLYWHEEL
11-2	SP-D450-D11-2	VENTILADOR DEL VOLANTE DE INERCIA	FLYWHEEL FAN
11-3	SP-D450-D11-3	VOLANTE DE INERCIA COMPLETO	FLYWHEEL
12	SP-D400-D12	ARANDELA Ø18	FLYWHEEL NUT WASHER Ø18
13	SP-D400-D13	TUERCA M18X1.5	FLYWHEEL NUT M18x1.5
14	SP-D400-D14	CAMPANA DE ARRANQUE	STARTING CLAW
14-1	SP-D450-D14-1	CAMPANA DE ARRANQUE	STARTING CLAW
15	SP-D400-D15	TORNILLO M6X12	FLANG BOLT M6x12
15-1	SP-D450-D15-1	TORNILLO M8X12	FLANG BOLT M8x12



SP-D400-D02



SP-D400-D06



SP-D400-D11



SP-D450-D11-2



SP-D450-D14-1



SP-D450-D11-3

FAST MOVING PARTS

RECOMMENDED PARTS

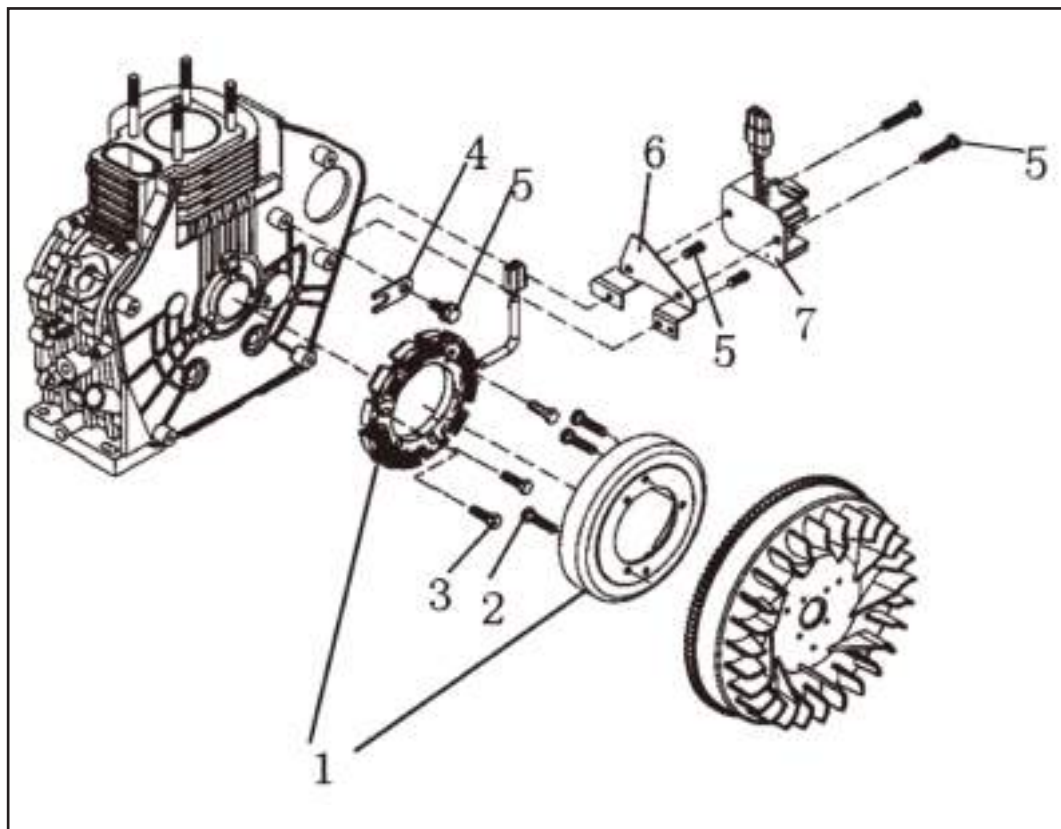

Nº	REF.	DESCRIPCIÓN (ES)	DESCRIPTION (EN)
1	SP-D400-E01	BOBINA CARGA MOTOR	FLYWHEEL ALTERNATOR
2	SP-D400-E02	TORNILLO M6X12	SCREW M6x12
3	SP-D400-E03	TORNILLO M6X22	SCREW M6x22
4	SP-D400-E04	PLACA FIJADOR CABLE	RETAINER PLATE
5	SP-D400-E05	TORNILLO M6X12	SCREW M6x12
6	SP-D400-E06	SOPORTE DE REGULADOR DE VOLTAJE	SUPPORT OF VOLTAGE REGULATOR
7	SP-D400-E07	REGULADOR/RECTIFICADOR DE CARGA	VOLTAGE REGULATOR ASSY



SP-D400-E01



SP-D400-E07

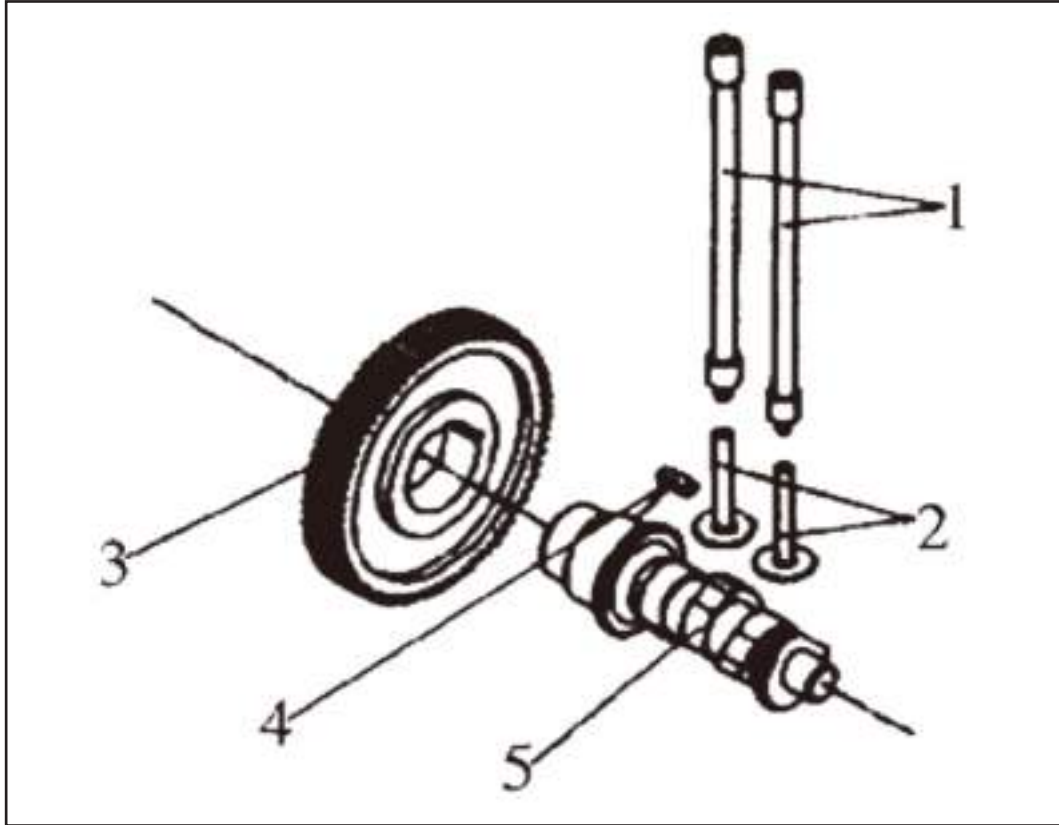

Nº	REF.	DESCRIPCIÓN (ES)	DESCRIPTION (EN)
1	SP-D400-F01	VARILLA DE EMPUJE (JUEGO) L=19,7cm	VALVE PUSH ROD ASSY L=19.7cm
1-1	SP-D450-F01-1	VARILLA DE EMPUJE (JUEGO) L=20,2cm	VALVE PUSH ROD ASSY L=20.2cm
1-2	SP-D500-F01-1	VARILLA DE EMPUJE (JUEGO) L=20,4cm	VALVE PUSH ROD ASSY L=20.4cm
2	SP-D400-F02	ASIENTO EMPUJADOR 7mm (JUEGO)	7mm VALVE TAPPET
2-1	SP-D500-F02	ASIENTO EMPUJADOR 8mm (JUEGO)	8mm VALVE TAPPET
3	SP-D400-F03	PIÑÓN ARBOL LEVAS	CAMSHAFT TIMING GEAR
4	SP-D400-F04	CHAVETA 5X14	KEY 5x14
5	SP-D400-F05	ARBOL DE LEVAS	CAMSHAFT
5-1	SP-D500-F05-1	ARBOL DE LEVAS	CAMSHAFT
5-2	SP-D500-F05-2	ARBOL DE LEVAS COMPLETO CON DESCOMPRESOR AUTOMATICO	CAMSHAFT



SP-D400-F01



SP-D400-F02



SP-D400-F05



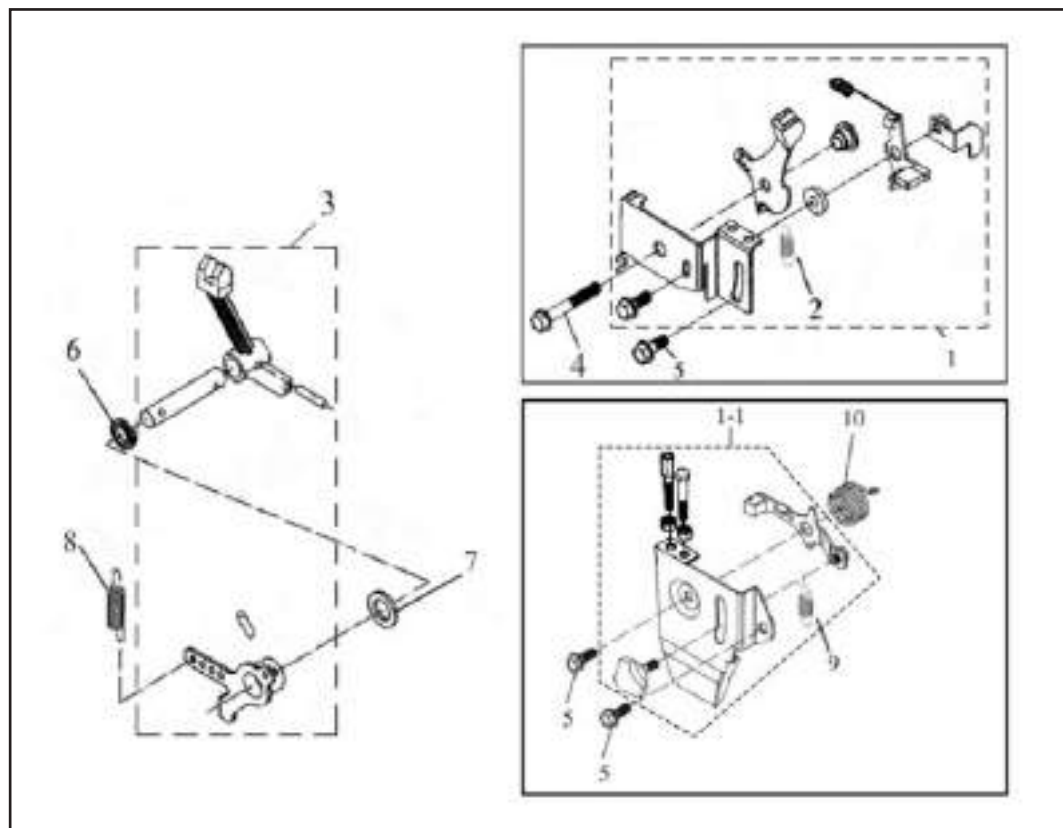

Nº	REF.	DESCRIPCIÓN (ES)	DESCRIPTION (EN)
1	SP-D400-G01	CONJUNTO CONTROLADOR DE VELOCIDAD STOP-START	STOP-START SPEED GOVERNOR ASSY
1-1	SP-D400-G01-1	CONJUNTO CONTROLADOR DE VELOCIDAD COMÚN	COMMON SPEED GOVERNOR ASSY
2	SP-D400-G02	MUELLE DE RETROCESO II	RETRUN SPRING II
3	SP-D400-G03	HORQUILLA INTERIOR MOTOR GOVERNADOR	GOVERNOR LEVEL ASSY
4	SP-D400-G04	TORNILLO M6X18	FLANGE BOLT M6×18
5	SP-D400-G05	TORNILLO M6X14	FLANGE BOLT M6×14
6	SP-D400-G06	RETEN Ø2,6XØ14X8	LEVEL SHAFT OIL SEAL Ø2.6XØ14X8
7	SP-D400-G07	ARANDELA	LEVEL SHAFT GASKET
8	SP-D400-G08	MUELLE ACELERADOR	GOVERNOR SPRING
9	SP-D400-G09	MUELLE DE RETROCESO I	RETURN SPRING I
10	SP-D400-G10	MUELLE	SPRING



SP-D400-G01



SP-D400-G01-1



SP-D400-G03

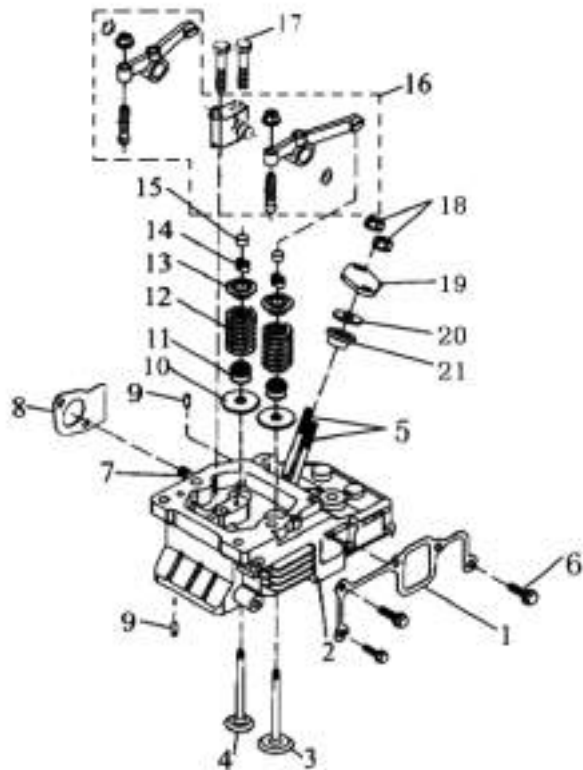

Nº	REF.	DESCRIPCIÓN (ES)	DESCRIPTION (EN)
1	SP-D400-H01	JUNTA COLECTOR ADMISION	INTAKE PIPE SHIM
1-1	SP-D500-H01-1	JUNTA COLECTOR ADMISION	INTAKE PIPE SHIM
2	SP-D400-H02	CULATA	CYLINDER HEAD
2-1	SP-D450-H02-1	CULATA	CYLINDER HEAD
2-2	SP-D500-H02-2	CULATA	CYLINDER HEAD
3	SP-D400-H03	VALVULA ADMISION	INTAKE VALVE
3-1	SP-D450-H03-1	VALVULA ADMISION	INTAKE VALVE
3-2	SP-D500-H03-2	VALVULA ADMISION	INTAKE VALVE
4	SP-D400-H04	VALVULA ESCAPE	EXHAUST VALVE
4-1	SP-D450-H04-1	VALVULA ESCAPE	EXHAUST VALVE
4-2	SP-D500-H04-2	VALVULA ESCAPE	EXHAUST VALVE
5	SP-D400-H05	TORNILLO DOBLE ROSCA AM6 x 55	STUD AM6x55
5-1	SP-D450-H05-1	TORNILLO DOBLE ROSCA AM6 x 55	STUD AM6x55
6	SP-D400-H06	TORNILLO M6 x 25	BOLT M6x25
7	SP-D400-H07	TORNILLO DOBLE ROSCA M8 x 20	STUD M8x20
7-1	SP-D450-H07-1	TORNILLO DOBLE ROSCA M10x25	STUD M10x25
8	SP-D400-H08	JUNTA ESCAPE CULATA	EXHAUST PIPE WASHER
8-1	SP-D500-H08-1	JUNTA ESCAPE CULATA	EXHAUST PIPE WASHER
9	SP-D400-H09	PIN 4 x 8	PIN 4x8
10	SP-D400-H10	ARANDELA BASE MUELLE	VALVE SPRING GASKET
10-1	SP-D500-H10-1	ARANDELA BASE MUELLE	VALVE SPRING GASKET
11	SP-D400-H11	RETEN VALVULA	VALVE CONDUIT OIL SEAL
12	SP-D400-H12	MUELLE VALVULA	VALVE SPRING
12-1	SP-D500-H12-1	MUELLE VALVULA	VALVE SPRING
13	SP-D400-H13	ASIENTO SUPERIOR MUELLE	VALVE SPRING SEAT
13-1	SP-D500-H13-1	ASIENTO SUPERIOR MUELLE	VALVE SPRING SEAT
14	SP-D400-H14	CONJUNTO CLIPS DE RETENCION DE LA VALVULA	VALVE RETAINING CLIPS ASSY
14-1	SP-D500-H14-1	CONJUNTO CLIPS DE RETENCION DE LA VALVULA	VALVE RETAINING CLIPS ASSY
15	SP-D400-H15	TOPE CABEZA DE LA VALVULA	VALVE AADJUSTING CUSHION
15-1	SP-D500-H15-1	TOPE CABEZA DE LA VALVULA	VALVE AADJUSTING CUSHION
16	SP-D400-H16	CONJUNTO BALANCINES	ROCK ARM ASSY
17	SP-D400-H17	TORNILLOS DEL CONJUNTO BALANCINES M8 x 1,25 x 50	SET BOLT OF ROCKER ARM SEAT M8x1.25x50
18	SP-D400-H18	TUERCA M6	FLANGE NUT M6
19	SP-D400-H19	PLACA FIJACION INYECTOR	FUEL INJECTION VALVE RETAINER
20	SP-D400-H20	ARANDELAS DE AJUSTE DEL INYECTOR 0,1~.5MM	INJECTOR ADJUSTMENT WASHERS (0.1-0.5MM AS OPTIONAL)
21	SP-D400-H21	CASQUILLO TERMICO	HEAT INSULATOR
22	SP-D400-H22	CULATA COMPLETA	CYLINDER HEAD ASSEMBLY



SP-D450-H02-1



SP-D450-H04-1



SP-D450-H03-1

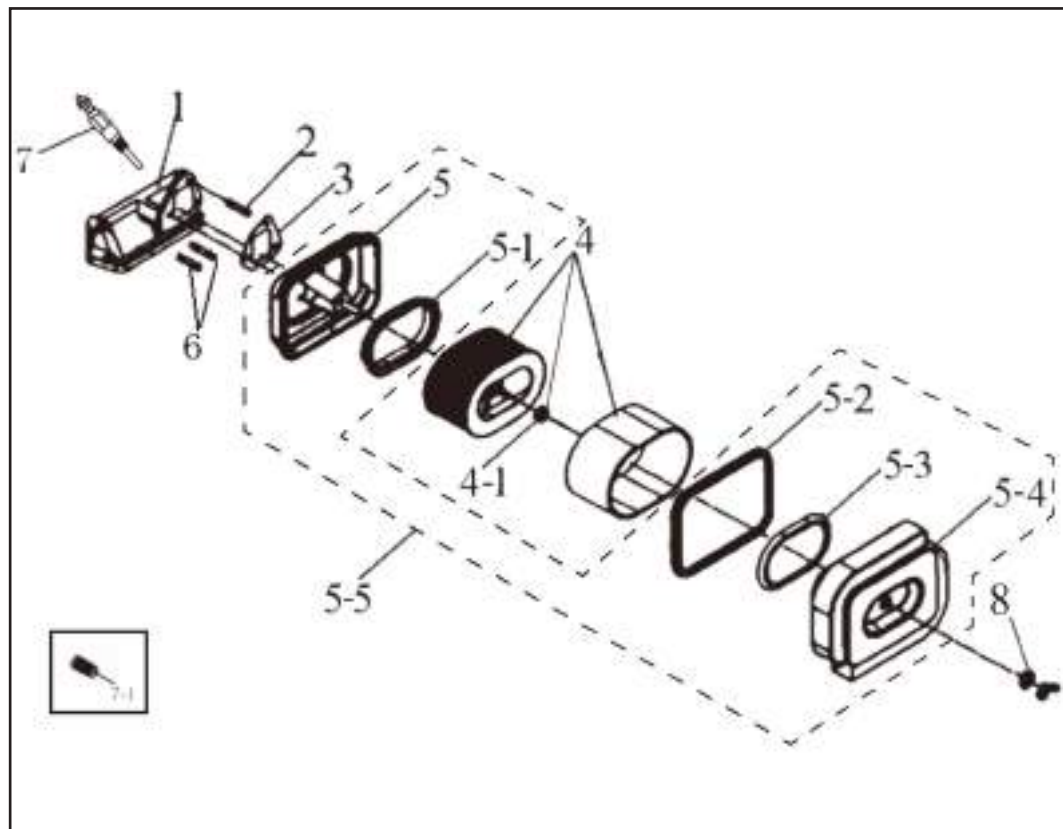

SP-D400-I04



SP-D400-I07



SP-D400-I09



SP-D400-I10-LE



SP-D400-I10-SE

Nº	REF.	DESCRIPCIÓN (ES)	DESCRIPTION (EN)
1	SP-D400-I01	TOBERA ADMISION	INLET PIPE
1-1	SP-D500-I01-1	TOBERA ADMISION	INLET PIPE
2	SP-D400-I02	TORNILLO M6X12	FLANG BOLT M6X12
3	SP-D400-I03	JUNTA TOBERA ADMISION A FILTRO	AIR CLEARNER GASKET
3-1	SP-D500-I03-1	JUNTA TOBERA ADMISION A FILTRO	AIR CLEARNER GASKET
4	SP-D400-I04	FILTRO DE AIRE COMPLETO PAPEL	AIR CLEANER ELEMENT ASSY
4-1	SP-D400-I04-1	GOMA TORNILLO FIJACION FILTRO	CLEANER RUBBER
4-2	SP-D400-I04-OIL	FILTRO DE AIRE COMPLETO BAÑADO EN ACEITE	AIR CLEANER ELEMENT ASSY OIL
5	SP-D400-I05-LE	TAPA TRASERA CAJA FILTRO AIRE	AIR CLEANER FRONT COVER
5-1	SP-D400-I05-1-LE	JUNTA GOMA CARCASA TRASERA FILTRO AIRE	AIR CLEANER FRONT RUBBER
5-2	SP-D400-I05-2-LE	JUNTA GOMA CIERRE CAJA FILTRO DE AIRE	AIR CLEANER JOINT
5-3	SP-D400-I05-3-LE	JUNTA GOMA TAPA FILTRO AIRE	AIR CLEANER BACK RUBBER
5-4	SP-D400-I05-4-LE	TAPA DELANTERA DEL FILTRO DE AIRE	AIR CLEANER BACK COVER
5-5	SP-D400-I05-5-LE	CAJA FILTRO AIRE SIN FILTRO	AIR FILTER CASE (NO FILTER)
5	SP-D400-I05-SE	TAPA TRASERA CAJA FILTRO AIRE	AIR CLEANER FRONT COVER
5-1	SP-D400-I05-1-SE	JUNTA GOMA CARCASA TRASERA FILTRO AIRE	AIR CLEANER FRONT RUBBER
5-2	SP-D400-I05-2-SE	JUNTA GOMA CIERRE CAJA FILTRO DE AIRE	AIR CLEANER JOINT
5-3	SP-D400-I05-3-SE	JUNTA GOMA TAPA FILTRO AIRE	AIR CLEANER BACK RUBBER
5-4	SP-D400-I05-4-SE	TAPA DELANTERA DEL FILTRO DE AIRE	AIR CLEANER BACK COVER
5-5	SP-D400-I05-5-SE	CAJA FILTRO AIRE SIN FILTRO	AIR FILTER CASE (NO FILTER)
5	SP-D500-I05-LE	TAPA TRASERA CAJA FILTRO AIRE	AIR CLEANER FRONT COVER
5-1	SP-D500-I05-1-LE	JUNTA GOMA CARCASA TRASERA FILTRO AIRE	AIR CLEANER FRONT RUBBER
5-2	SP-D500-I05-2-LE	JUNTA GOMA CIERRE CAJA FILTRO DE AIRE	AIR CLEANER JOINT
5-3	SP-D500-I05-3-LE	JUNTA GOMA TAPA FILTRO AIRE	AIR CLEANER BACK RUBBER
5-4	SP-D500-I05-4-LE	TAPA DELANTERA DEL FILTRO DE AIRE	AIR CLEANER BACK COVER
5-5	SP-D500-I05-5-LE	CAJA FILTRO AIRE SIN FILTRO	AIR FILTER CASE (NO FILTER)
5	SP-D500-I05-SE	TAPA TRASERA CAJA FILTRO AIRE	AIR CLEANER FRONT COVER
5-1	SP-D500-I05-1-SE	JUNTA GOMA CARCASA TRASERA FILTRO AIRE	AIR CLEANER FRONT RUBBER
5-2	SP-D500-I05-2-SE	JUNTA GOMA CIERRE CAJA FILTRO DE AIRE	AIR CLEANER JOINT
5-3	SP-D500-I05-3-SE	JUNTA GOMA TAPA FILTRO AIRE	AIR CLEANER BACK RUBBER
5-4	SP-D500-I05-4-SE	TAPA DELANTERA DEL FILTRO DE AIRE	AIR CLEANER BACK COVER
5-5	SP-D500-I05-5-SE	CAJA FILTRO AIRE SIN FILTRO	AIR FILTER CASE (NO FILTER)

FAST MOVING PARTS

RECOMMENDED PARTS

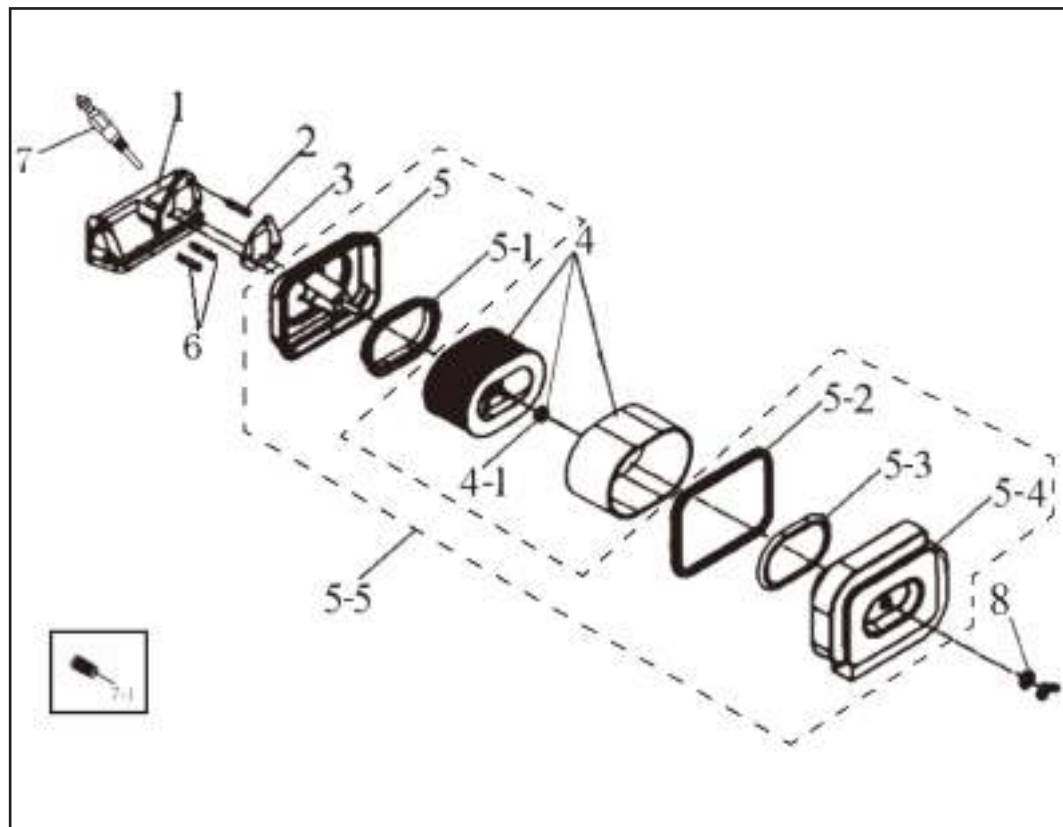

Nº	REF.	DESCRIPCIÓN (ES)	DESCRIPTION (EN)
6	SP-D400-I06	TORNILLO DOBLE M6X75	BOLT M6X75
7	SP-D400-I07	PRE-CALENTADOR 12V	12V HEATING PLUG
7-1	SP-D400-I07-1	TORNILLO HEXAGONAL INTERNO	HEXAGONAL INTERNAL SCREW PLUG
8	SP-D400-I08	TORNILLO CIERRE CARCASA	BACK SCREW
9	SP-D400-I09	FILTRO AIRE COMPLETO >22	AIR CLEANER ELEMENT ASSY >22
10	SP-D400-I10-LE	CAJA FILTRO AIRE PLASTICO LE	AIR FILTER PLASTIC BOX LE
10-1	SP-D400-I10-SE	CAJA FILTRO AIRE PLASTICO SE	AIR FILTER PLASTIC BOX SE
10-2	SP-D500-I10-LE	CAJA FILTRO AIRE PLASTICO LE	AIR FILTER PLASTIC BOX LE
10-3	SP-D500-I10-SE	CAJA FILTRO AIRE PLASTICO SE	AIR FILTER PLASTIC BOX SE
11	AC-KITMAN-D400	CONJUNTO MANTENIMIENTO FILTROS PARA MOTOR D400/450/500	MAINTENANCE KIT ASSY FOR ENGINES D400/450/500
11-1	SP-KITMAN-D400-C	CONJUNTO FILTROS PARA MOTOR D400/450/500 >22	KIT ASSY FOR ENGINES D400/450/500 >22
11-2	AC-KITMAN-DIESEL3	KIT MANTENIMIENTO COMPLETO 3000 rpm	3000 rpm COMPLETE MAINTENANCE KIT



SP-D400-I04



SP-D400-I07



SP-D400-I09



SP-D400-I10-LE



SP-D400-I10-SE

FAST MOVING PARTS

RECOMMENDED PARTS

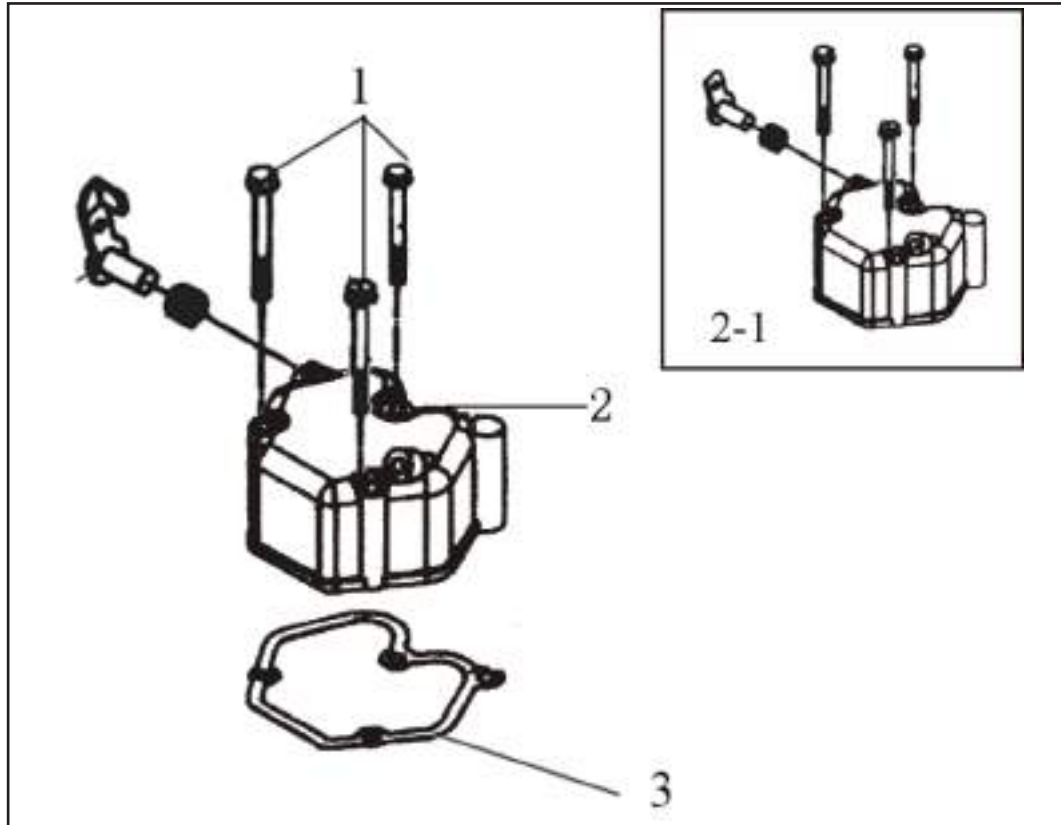

Nº	REF.	DESCRIPCIÓN (ES)	DESCRIPTION (EN)
1	SP-D400-J01	TORNILLO M6 x 70	BOLT M6x70
2	SP-D400-J02	TAPA VALVULAS (MOTORES, GENERADORES)	CYLINDER HEAD COVER ASSY(ENGINE, GENERATOR)
2-1	SP-D400-J02-1	TAPA VALVULAS (MOTO BOMBA)	CYLINDER HEAD COVER ASSY(PUMP SET)
2-2	SP-D500-J02-2	TAPA VALVULAS (GENERADOR)	CYLINDER HEAD COVER ASSY (GENERATOR SET)
3	SP-D400-J03	JUNTA TAPA VALVULAS	CYLINDER HEAD COVER GASKET
3-1	SP-D500-J03-1	JUNTA TAPA VALVULAS	CYLINDER HEAD COVER GASKET



SP-D400-J02



SP-D400-J02-1



SP-D400-J02



SP-D500-J02-2

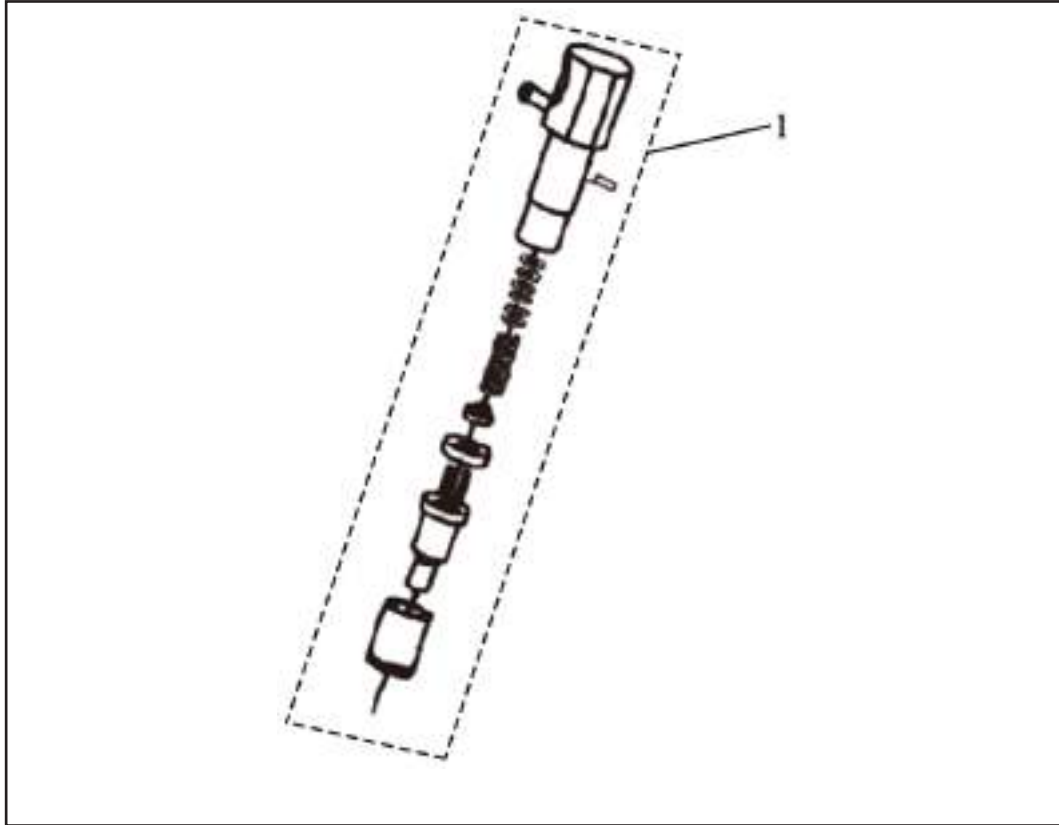

Nº	REF.	DESCRIPCIÓN (ES)	DESCRIPTION (EN)
1	SP-D400-K01	INYECTOR CONJUNTO	INJECTOR ASSY
1-1	SP-D400-K01-1	INYECTOR CONJUNTO MODELO NO FA	INJECTOR ASSY NO FA
1-2	SP-D450-K01-1	INYECTOR CONJUNTO	INJECTOR ASSY
1-3	SP-D500-K01-2	INYECTOR CONJUNTO	INJECTOR ASSY



SP-D400-K01



SP-D450-K01-1



SP-D500-K01-2

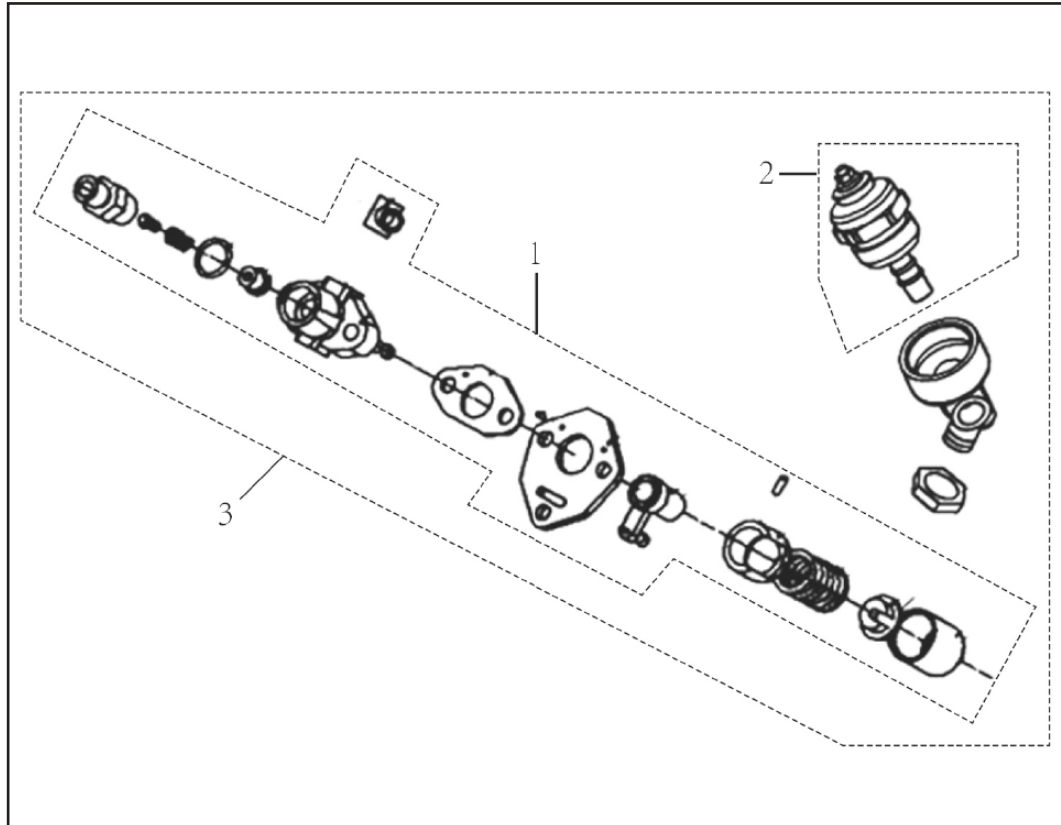

Nº	REF.	DESCRIPCIÓN (ES)	DESCRIPTION (EN)
1	SP-D400-L01	BOMBA INYECCION (SIN ELECTRO VALVULA) PARA MOTOBOMBAS	INJECTION PUMP ASSY
2	SP-D400-L02	VALVULA ELECTROMAGNETICA	ELECTROMAGNETIC VALVE
3	SP-D400-L03	BOMBA INYECCION CON ELECTRO VALVULA	INJECTION PUMP ASSY(ELECTROMAGNETIC VALVE INCLUDED)
3-1	SP-D450-L03-1	BOMBA INYECCION CON ELECTRO VALVULA	INJECTION PUMP ASSY(ELECTROMAGNETIC VALVE INCLUDED)
3-2	SP-D500-L03-2	BOMBA INYECCION CON ELECTRO VALVULA	INJECTION PUMP ASSY(ELECTROMAGNETIC VALVE INCLUDED)



SP-D400-L02



SP-D400-L03



SP-D500-L03-2

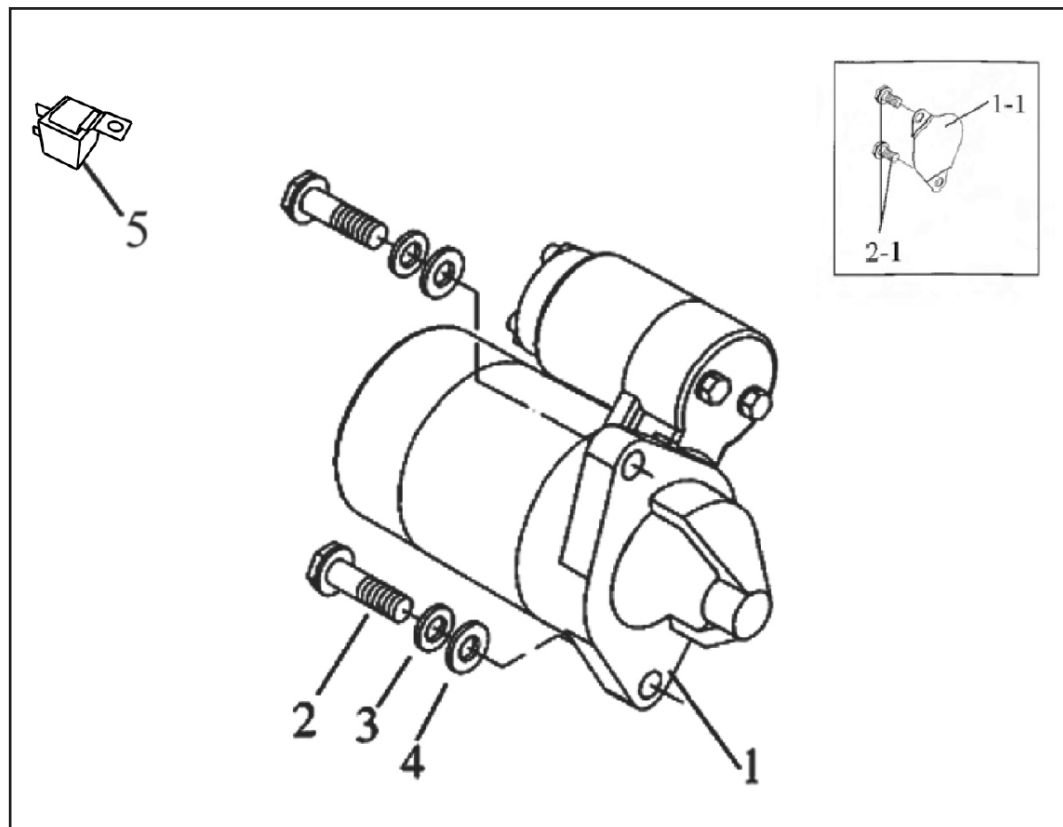

Nº	REF.	DESCRIPCIÓN (ES)	DESCRIPTION (EN)
1	SP-D400-M01	MOTOR DE ARRANQUE D400/450/500	STARTING MOTOR ASSY
1-1	SP-D400-M01-1	MOTOR DE ARRANQUE LE	STARTING MOTOR
2	SP-D400-M02	TORNILLO M10x35	BOLT M10x35
2-1	SP-D400-M02-1	TORNILLO M10x20	BOLT M10x20
3	SP-D400-M03	JUNTA DE MUELLE Ø10	SPRING GASKET Ø10
4	SP-D400-M04	ARANDELA PLANA Ø10	FLAT WASHER Ø10
5	SP-D400-M05	RELE MOTOR ARRANQUE 60A	STARTER ENGINE RELAY 60A
5-1	SP-D400-M05-1	RELE MOTOR ARRANQUE 80A	STARTER ENGINE RELAY 80A
6	SP-D400-M06	PORTAFUSIBLES CONJUNTO	FUSE HOLDER ASSY



SP-D400-M01



SP-D400-M05



SP-D400-M06



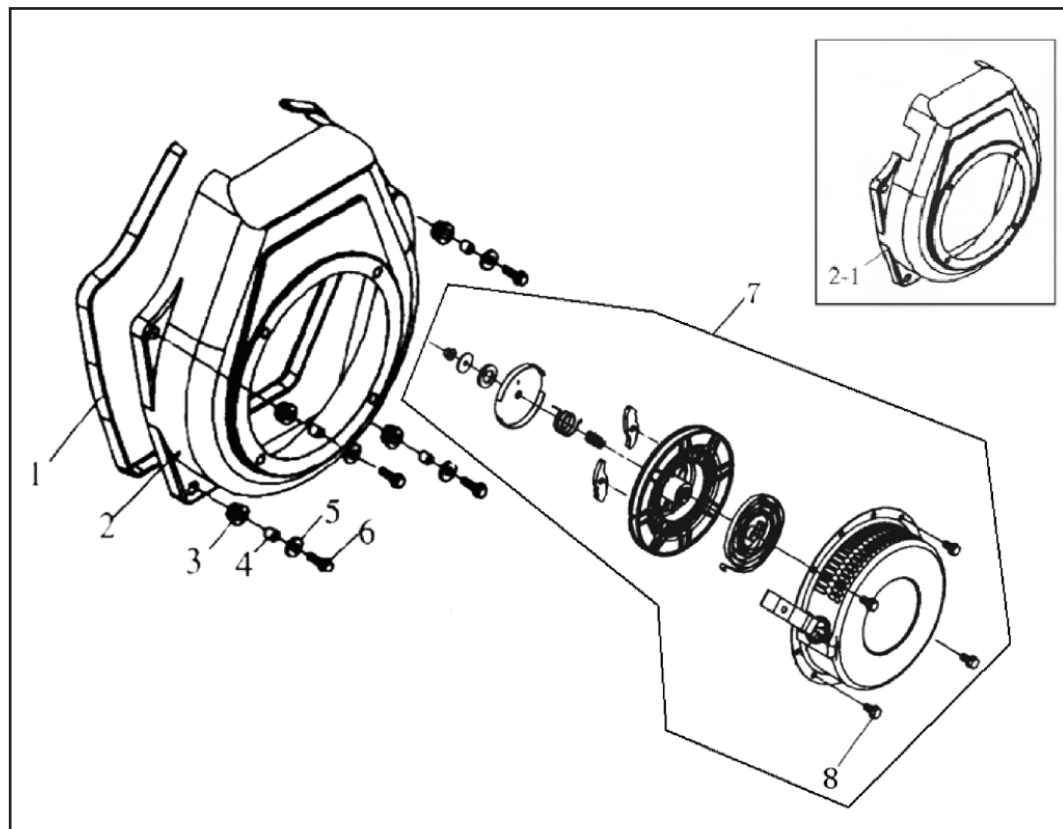

Nº	REF.	DESCRIPCIÓN (ES)	DESCRIPTION (EN)
1	SP-D400-N01	GOMA PROTECCION CARCASA	CUSHION
2	SP-D400-N02	CUBIERTA VOLANTE DE INERCIA (MODELO LE METALICO)	FAN COVER WELDMENT ASSY (METALIC OPEN FRAME TYPE)
2-1	SP-D400-N02-1	CUBIERTA VOLANTE DE INERCIA (MODELO SE METALICO)	FAN COVER WELDMENT ASSY (METALIC SOUNDPROOF TYPE)
2-2	SP-D400-N02-2	CUBIERTA VOLANTE INERCIA (MODELO LE PLASTICO)	FAN COVER WELDMENT ASSY (PLASTIC OPEN FRAME TYPE)
2-3	SP-D400-N02-3	CUBIERTA VOLANTE INERCIA (MODELO SE PLASTICO)	FAN COVER WELDMENT ASSY (PLASTIC SOUNDPROOF TYPE)
2-2	SP-D450-N02-2	CUBIERTA VOLANTE DE INERCIA (MODELO LE)	FAN COVER WELDMENT ASSY (OPEN FRAME TYPE)
2-3	SP-D450-N02-3	CUBIERTA VOLANTE DE INERCIA (MODELO SE)	FAN COVER WELDMENT ASSY (SOUNDPROOF TYPE)
2-2	SP-D500-N02	CUBIERTA VOLANTE INERCIA (MODELO LE METALICO)	FAN COVER WELDMENT ASSY (METALIC OPEN FRAME TYPE)
2-1	SP-D500-N02-1	CUBIERTA VOLANTE INERCIA (MODELO SE METALICO)	FAN COVER WELDMENT ASSY (METALIC SOUNDPROOF TYPE)
2-4	SP-D500-N02-4	CUBIERTA VOLANTE DE INERCIA (MODELO LE PLASTICO)	FAN COVER WELDMENT ASSY (PLASTIC OPEN FRAME TYPE)
2-5	SP-D500-N02-5	CUBIERTA VOLANTE DE INERCIA (MODELO SE PLASTICO)	FAN COVER WELDMENT ASSY (PLASTIC SOUNDPROOF TYPE)
3	SP-D400-N03	GOMA ANTIVIBRACION	CUSHION SHEATH
4	SP-D400-N04	CASQUILLO	SHEATH
5	SP-D400-N05	ARANDELA PLANA Ø6	FLAT WASHER Ø6
6	SP-D400-N06	TORNILLO M6 x 22	BOLT M6x22
7	SP-D400-N07	ARRANCADOR MANUAL COMPLETO	STARTER ASSY
8	SP-D400-N08	TORNILLO M6X8	SCREW M6X8



SP-D450-N02-2



SP-D450-N02-3



SP-D400-N07

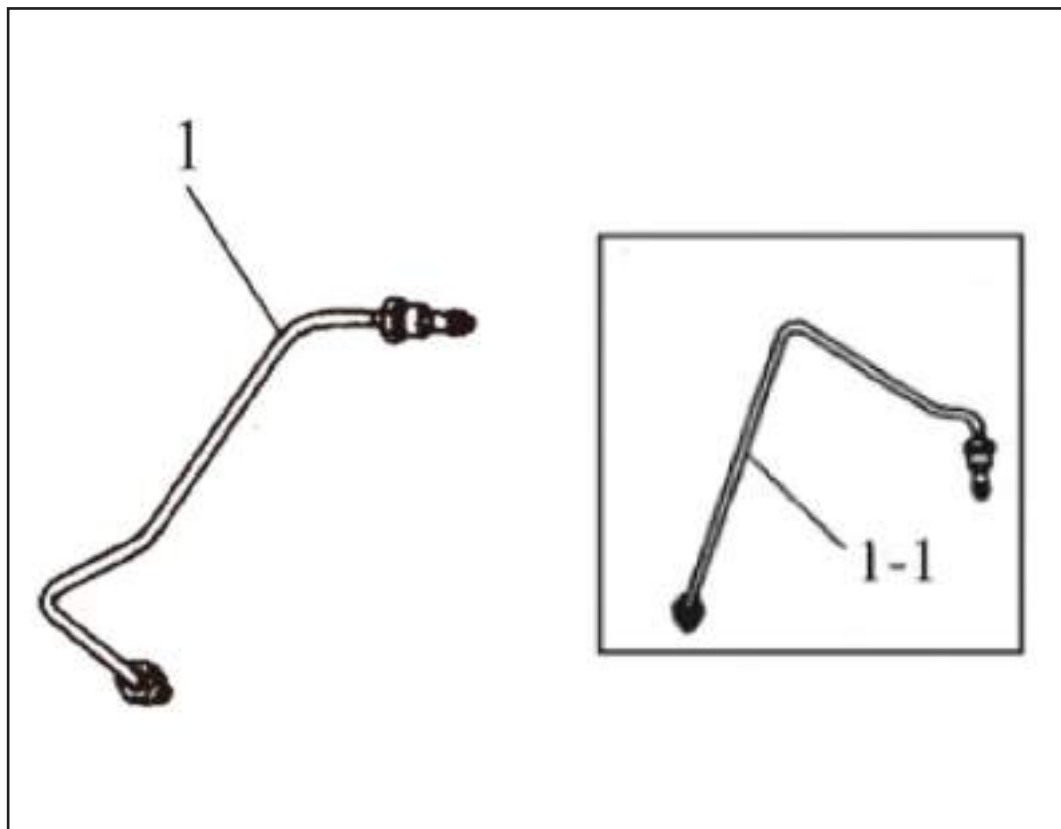

Nº	REF.	DESCRIPCIÓN (ES)	DESCRIPTION (EN)
1	SP-D400-001	TUBO DE ALTA PRESION (MODELO LE)	HIGH-PRESSURE TUBE (OPEN FRAME TYPE)
1-1	SP-D400-001-1	TUBO DE ALTA PRESION (MODELO SE)	HIGH-PRESSURE TUBE(SOUNDPROOF TYPE)
1	SP-D450-01	TUBO DE ALTA PRESION (MODELO LE)	HIGH-PRESSURE TUBE (OPEN FRAME TYPE)
1-1	SP-D450-01-1	TUBO DE ALTA PRESION (MODELO SE)	HIGH-PRESSURE TUBE(SOUNDPROOF TYPE)
2	SP-D400-002	ABRAZADERA TUBO COMBUSTIBLE RETORNO	FUEL RETURN PIPE CLAMP
3	SP-D400-003	ABRAZADERA TUBO COMBUSTIBLE	FUEL PIPE CLAMP



SP-D400-001



SP-D400-001-1



SP-D450-01



SP-D450-01-1



SP-D400-002



SP-D400-003

FAST MOVING PARTS

RECOMMENDED PARTS

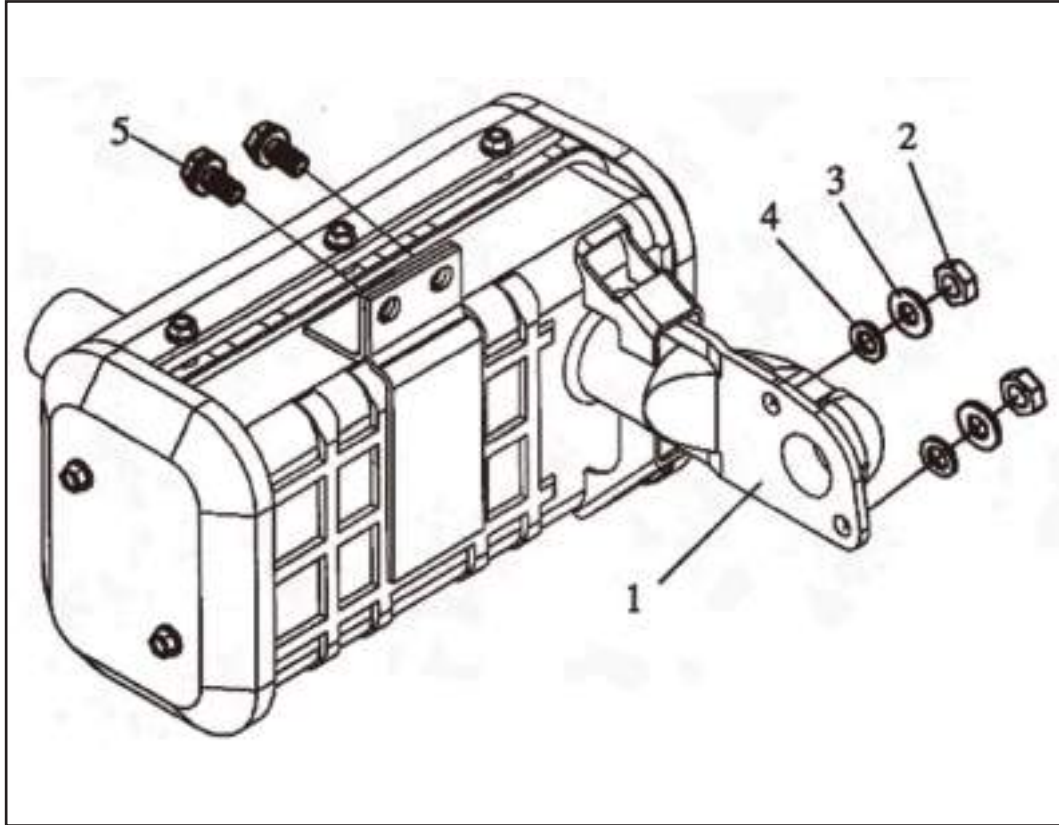

Nº	REF.	DESCRIPCIÓN (ES)	DESCRIPTION (EN)
1	SP-D400-P01	SILENCIADOR ESCAPE CON PROTECTOR	MUFFLER(ENGINE TYPE WITH PROTECTION COVER)
1-2	SP-D500-P01-2	SILENCIADOR ESCAPE CON PROTECTOR	MUFFLER(ENGINE TYPE WITH PROTECTION COVER)
2	SP-D400-P02	TUERCA M8	NUT M8
3	SP-D400-P03	ARANDELA DE BLOQUEO Ø8	SPRING WASHER Ø8
4	SP-D400-P04	ARANDELA PLANA Ø8	FLAT WASHER Ø8
5	SP-D400-P05	TORNILLO M8 × 16	FLANGE BOLT M8×16



SP-D400-P01

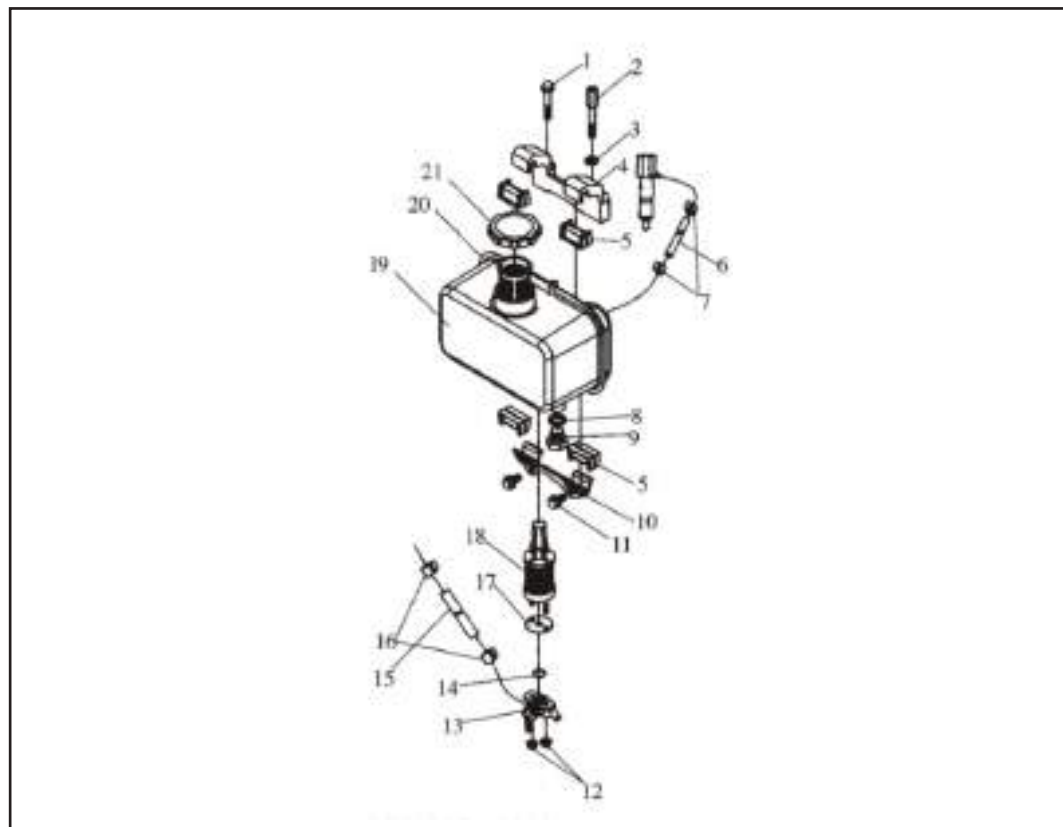

Nº	REF.	DESCRIPCIÓN (ES)	DESCRIPTION (EN)
1	SP-D400-Q01	TORNILLO M8X45	BOLT M8X45
2	SP-D400-Q02	TORNILLO DE SOPORTE SUPERIOR DEL DEPOSITO DE COMBUSTIBLE	SET BOLT OF FUEL TANK UPPER SUPPORT
3	SP-D400-Q03	ARANDELA Ø8	GASKET Ø8
4	SP-D400-Q04	SOPORTE SUPERIOR DEL DEPOSITO DE COMBUSTIBLE	FUEL TANK UPPER SUPPORT
5	SP-D400-Q05	GOMA ANTIVIBRACION	CUSHION
6	SP-D400-Q06	TUBERIA DE RETORNO DE COMBUSTIBLE	FUEL RETURN PIPE
7	SP-D400-Q07	ABRAZADERA TUBO RETORNO	FUEL RETURN PIPE CLIP
8	SP-D400-Q08	JUNTA SALIDA DEPOSITO	DRAIN BOLT WASHER
9	SP-D400-Q09	TORNILLO M12*1.25*14	BOLT M12*1.25*14
10	SP-D400-Q10	SOPORTE INFERIOR DEPOSITO COMBUSTIBLE	FUEL TANK LOWER SUPPORT
11	SP-D400-Q11	TUERCA M6*14	NUT M6*14
12	SP-D400-Q12	TUERCA M6	NUT M6
13	SP-D400-Q13	GRIFO DEPOSITO COMBUSTIBLE	FUEL TANK SWITCH ASSEM.
14	SP-D400-Q14	JUNTA TORICA	O-RING
15	SP-D400-Q15	TUBERIA DE COMBUSTIBLE	FUEL PIPE
16	SP-D400-Q16	ABRAZADERA TUBO COMBUSTIBLE	CLIP
17	SP-D400-Q17	JUNTA FILTRO COMBUSTIBLE	FUEL FILTER WASHER
18	SP-D400-Q18	FILTRO INTERIOR DEPOSITO COMBUSTIBLE (6CM)	ELEMENT ASSY (6CM)
18-1	SP-D400-Q18-1	FILTRO INTERIOR DEPOSITO COMBUSTIBLE (8,3CM)	ELEMENT ASSY (8,3CM)
18-2	SP-D400-Q18-2	FILTRO INTERIOR DEPOSITO COMBUSTIBLE (10,8CM)	ELEMENT ASSY (10,8CM)
19	SP-D400-Q19	DEPOSITO COMBUSTIBLE 5,5LT	FUEL TANK WELDMENT ASSY
20	SP-D400-Q20	PRE-FILTRO DEPOSITO COMBUSTIBLE	FUEL FILLER SCREEN
21	SP-D400-Q21	TAPON DEPOSITO COMBUSTIBLE MOTOBOMBA	FUEL TANK CAP
22	SP-D400-Q22	DEPOSITO DE COMBUSTIBLE COMPLETO	FUEL TANK ASSY



SP-D400-Q13



SP-D400-Q20

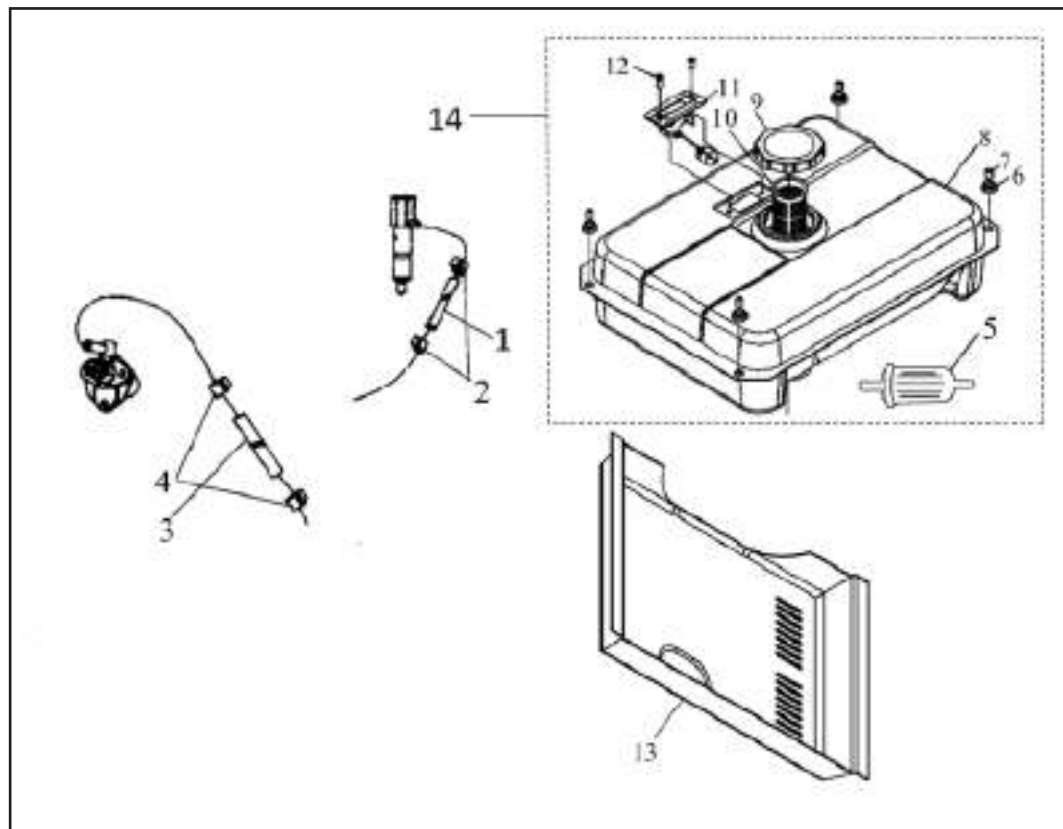

Nº	REF.	DESCRIPCIÓN (ES)	DESCRIPTION (EN)
1	SP-D400-R01	TUBO DE RETORNO DE COMBUSTIBLE Ø5x9.5	FUEL RETURN PIPE Ø5x9.5
2	SP-D400-R02	ABRAZADERA TUBO DE RETORNO DE COMBUSTIBLE Ø9	FUEL RETURN PIPE CLIP Ø9
3	SP-D400-R03	TUBO DE COMBUSTIBLE Ø7.5 x 13	FUEL PIPE Ø7.5x13
4	SP-D400-R04	ABRAZADERA TUBO DE COMBUSTIBLE Ø11, Ø13 (OPCIONAL)	FUEL PIPE CLIP Ø11, Ø13 AS OPTIONAL
5	SP-D400-R05	<b>FILTRO DE COMBUSTIBLE EXTERNO</b>	<b>EXTERNAL FUEL FILTER</b>
5-1	SP-D400-R05-1	FILTRO COMBUSTIBLE ANTIGUO ( VASO )	FUEL FILTER
6	SP-D400-R06	GOMAS ANTIVIBRACION DEPÓSITO	VIBRATION ISOLATION CUSHION BLOCK
7	SP-D400-R07	CASQUILLO	SHEATH
8	SP-D400-R08	DEPOSITO DE COMBUSTIBLE (TIPO ABIERTO)	FUEL TANK (OPEN FRAME TYPE)
8-1	SP-D400-R08-1	DEPOSITO DE COMBUSTIBLE 12L (TIPO INSONORIZADO)	FUEL TANK 12L (SOUNDPROOF TYPE)
8-2	SP-D500-R08-2	DEPOSITO DE COMBUSTIBLE 28L (6600SE-LRS)	FUEL TANK 28L (6600SE-LRS)
8-3	SP-D500-R08-3	DEPOSITO DE COMBUSTIBLE 25L (CAMO)	FUEL TANK 25L (CAMO)
9	SP-D400-R09	<b>TAPON DEL DEPÓSITO GENERADOR</b>	<b>FUEL TANK CAP</b>
10	SP-D400-R10	<b>PRE FILTRO COMBUSTIBLE</b>	<b>FUEL FILLER SCREEN</b>
11	SP-D400-R11	INDICADOR NIVEL DE COMBUSTIBLE (TIPO ABIERTO)	FUEL LEVEL INDICATOR ASSY (OPEN FRAME TYPE)
11-1	SP-D400-R11-1	INDICADOR NIVEL DE COMBUSTIBLE (TIPO INSONORIZADO)	FUEL LEVEL INDICATOR ASSY (SOUNDPROOF TYPE)
12	SP-D400-R12	TORNILLO M5x8	SCREW M5x8
13	SP-D400-R13	TAPA SUPERIOR	UPPER COVER
14	SP-D400-R14	CONJUNTO DEPÓSITO COMPLETO (TIPO ABIERTO NEGRO)	FUEL TANK (OPEN FRAME TYPE) COMPLETE ASSY BLACK
14-1	SP-D400-R14-1	CONJUNTO DEPÓSITO COMPLETO (TIPO ABIERTO AMARILLO)	FUEL TANK (OPEN FRAME TYPE) COMPLETE ASSY YELLOW
15	SP-D400-R15	TAPA GOMA DESCOMPRESOR	DECOMPRESSOR RUBBER COVER



SP-D400-R05



SP-D400-R08



SP-D400-R08-1



SP-D400-R15



SP-D500-R08-3



SP-D500-R08-2

FAST MOVING PARTS

RECOMMENDED PARTS

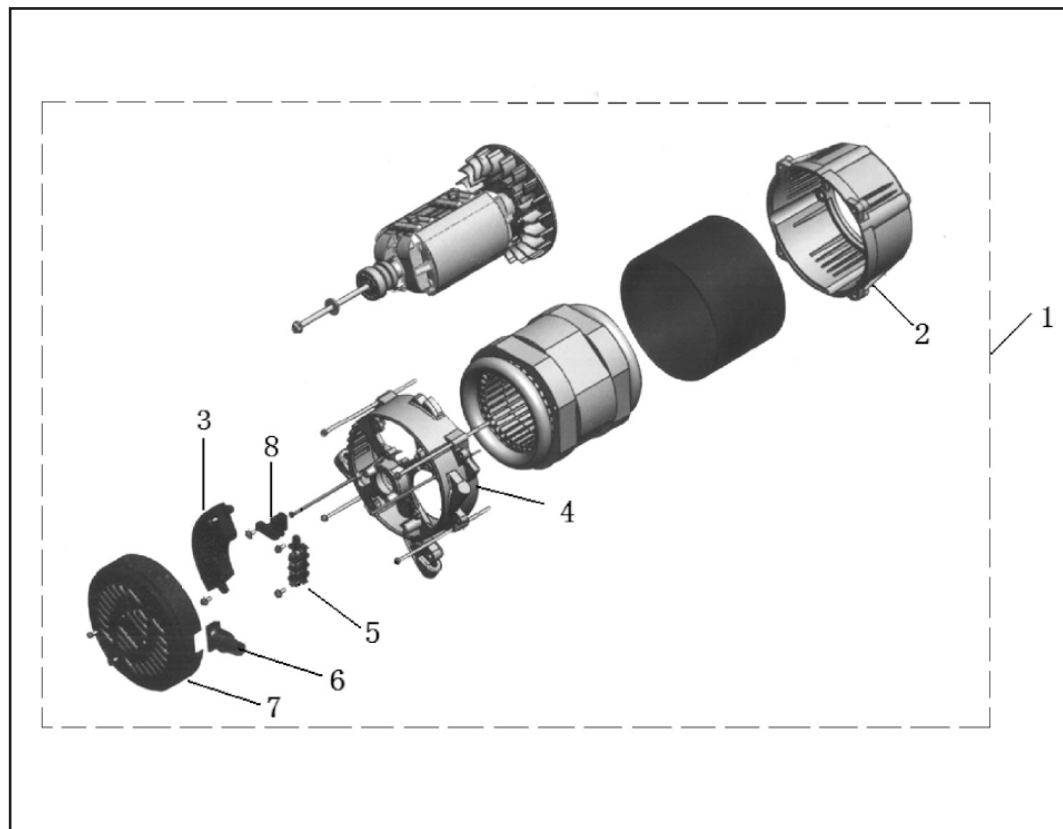

Nº	REF.	DESCRIPCIÓN (ES)	DESCRIPTION (EN)
1	SP-ALT-5	ALTERNADOR 5 KW MONOFASICO	5 KW MONOPHASE ALTERNATOR
1-1	SP-ALT-5-3	ALTERNADOR 5 KW TRIFASICO	5 KW THREE PHASE ALTERNATOR
1-2	SP-ALT-5-C	ALTERNADOR 5 KW MONOFASICO CORTOS	5 KW SHORT MONOPHASE ALTERNATOR
1-3	SP-ALT-5-LRS	ALTERNADOR 5 KW MONOFASICO PARA DHY6600SE-LRS	5 KW MONOPHASE ALTERNATOR FOR DHY6600SE-LRS
1-4	SP-ALT-5-SE	ALTERNADOR 5 KW MONOFÁSICO SILENCIOSO SIN AVR	5 KW SILENT MONOPHASE ALTERNATOR WITHOUT AVR
1-5	SP-ALT-5-3-SE	ALTERNADOR 5 KW TRIFÁSICO PARA SILENCIOSO COMPLETO.	5 KW THREE PHASE SILENT ALTERNATOR
1-6	SP-ALT-6-D	ALTERNADOR 6 KW MONOFASICO	6 KW MONOPHASE ALTERNATOR
1-7	SP-ALT-6T	ALTERNADOR 6 KW FULL POWER (COMPLETO)	6 KW FULL POWER ALTERNATOR (COMPLETE)
1-8	SP-ALT-6-LRS	ALTERNADOR 6 KW MONOFASICO PARA DHY8000SE-LRS	6KW MONOPHASE ALTERNATOR FOR DHY8000SE-LRS
1-9	SP-ALT-6-3	ALTERNADOR 6 KW TRIFASICO	6 KW THREE PHASE ALTERNATOR
1-10	SP-ALT-6-3-1	ALTERNADOR 6 KW TRIFÁSICO COMPLETO (CON AVR Y SIN CAMPANA)	6 KW THREE PHASE ALTERNATOR (WITH AVR)
1-11	SP-ALT-6-3-230V	ALTERNADOR 6 KW TRIFASICO A 230V	6 KW 230 V THREE PHASE ALTERNATOR
1-12	SP-ALT-6-3-LE	ALTERNADOR 6 KW TRIFÁSICO PARA LE (COMPLETO)	6 KW THREE PHASE ALTERNATOR FOR LE (COMPLETE)
2	SP-D400-S02	CUBIERTA DELANTERA (LE/LE-3) (TIPO ABIERTO)	FRONT ROUND COVER (LE/LE-3) (OPEN TYPE)
2-1	SP-D400-S02-1	CUBIERTA DELANTERA (SE/SE-3) (TIPO INSONORIZADO)	FRONT ROUND COVER (SE/SE-3) (SOUNDPROOF TYPE)
2-2	SP-D500-S02-2	CUBIERTA DELANTERA Ø204 ENCAJE 5MM (LE)	FRONT COVER Ø204 LACE 5MM (LE)
2-3	SP-D500-S02-3	CUBIERTA DELANTERA Ø204 ENCAJE 5MM (SE)	FRONT COVER Ø204 LACE 5MM (SE)



SP-D400-S02

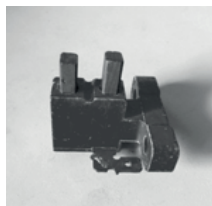

SP-ALT-ESC-5



SP-ALT-AVR-5



SP-ALT-AVR-5-2C



SP-D500-S04-2

FAST MOVING PARTS

RECOMMENDED PARTS

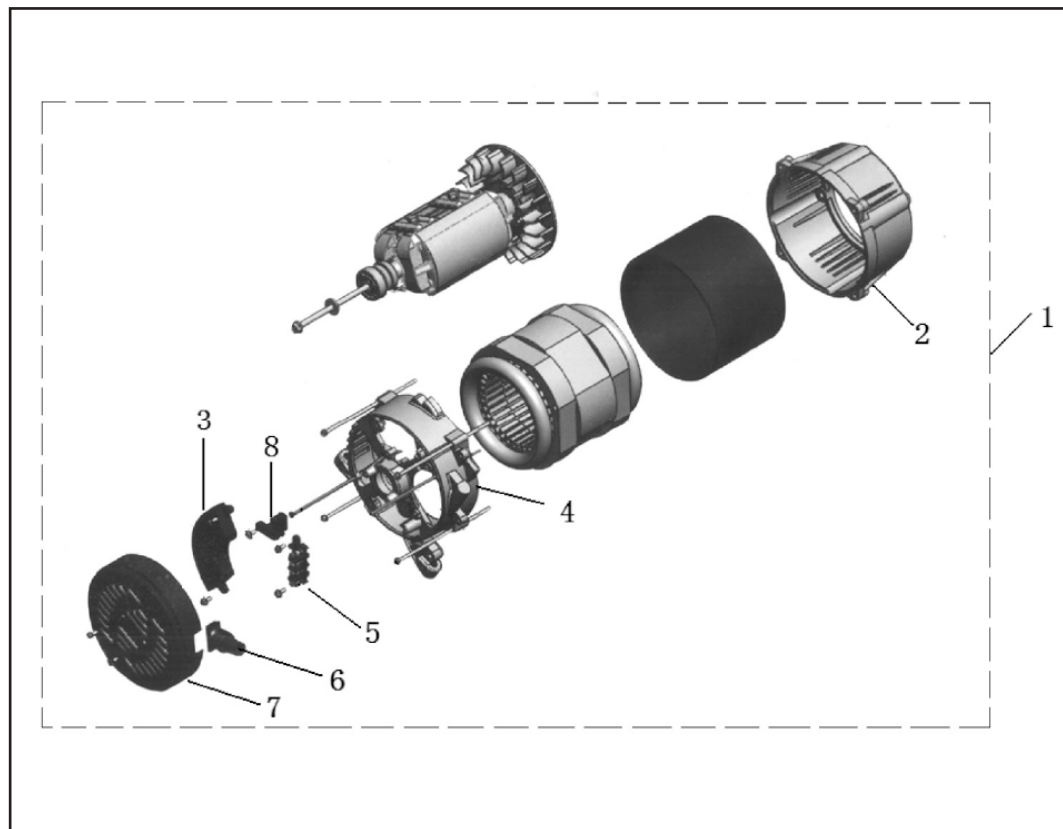

Nº	REF.	DESCRIPCIÓN (ES)	DESCRIPTION (EN)
3	SP-ALT-AVR-5	AVR 5/6KW MONOFASICO	AVR 5/6KW MONOPHASE
3-1	SP-ALT-AVR-5-SE	AVR 5/6KW MONOFASICO SILENCIOSOS	AVR 5/6KW MONOPHASE SOUNDPROOF
3-2	SP-ALT-AVR-5-3	AVR 5/6KW TRIFASICO 230V	AVR 5/6KW THREE PHASE 230V
3-3	SP-ALT-AVR-5-2C	AVR 5/6KW TRIFASICO DE 2 CONECTORES-8 CABLES	AVR 5/6KW THREE PHASE 2 CONNECT- 8 CABLES
3-4	SP-ALT-AVR-5-2C-7C	AVR 5/6KW TRIFASICO DE 2 CONECTORES-7 CABLES	AVR 5/6KW THREE PHASE 2 CONNECT- 7 CABLES
3-5	SP-ALT-AVR-5-SE-3	AVR 5/6KW TRIFASICO SILENCIOSOS	AVR 5/6KW THREE PHASE SOUNDPROOF
3-6	SP-ALT-AVR-6-T	AVR 6 KW FULL POWER	AVR 6KW FULL POWER
3-7	SP-ALT-AVR-7	AVR 7/8 KW MONOFÁSICO	AVR 7/8KW MONOPHASE
3-8	SP-ALT-AVR-7-3	AVR 7/8 KW TRIFÁSICO	AVR 7/8 THREE PHASE
3-9	SP-ALT-AVR-7-T	AVR 7/8 KW FULL POWER	AVR 7/8KW FULL POWER
4	SP-D400-S04	TAPA TRASERA Ø190 ENCAJE 3MM	REAR COVER Ø190 LACE 3MM
4-1	SP-D400-S04-1	TAPA TRASERA Ø190 ENCAJE 6MM	REAR COVER Ø190 LACE 6MM
4-2	SP-D500-S04-2	TAPA TRASERA Ø204 ENCAJE 5MM	REAR COVER Ø204 LACE 5MM
5	SP-D400-S05	PLACA TERMINAL	TERMINAL PLATE
6	SP-D400-S06	CUBIERTA DEL CABLE DE GOMA	RUBBER CABLE COVER
7	SP-D400-S07	CUBIERTA TRASERA	REAR END COVER
8	SP-ALT-ESC-5	ESCOBILLAS	BRUSH KIT



SP-D400-S02

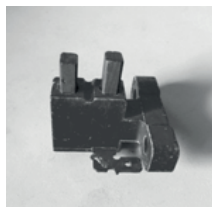

SP-ALT-ESC-5



SP-ALT-AVR-5



SP-ALT-AVR-5-2C



SP-D500-S04-2

FAST MOVING PARTS

RECOMMENDED PARTS

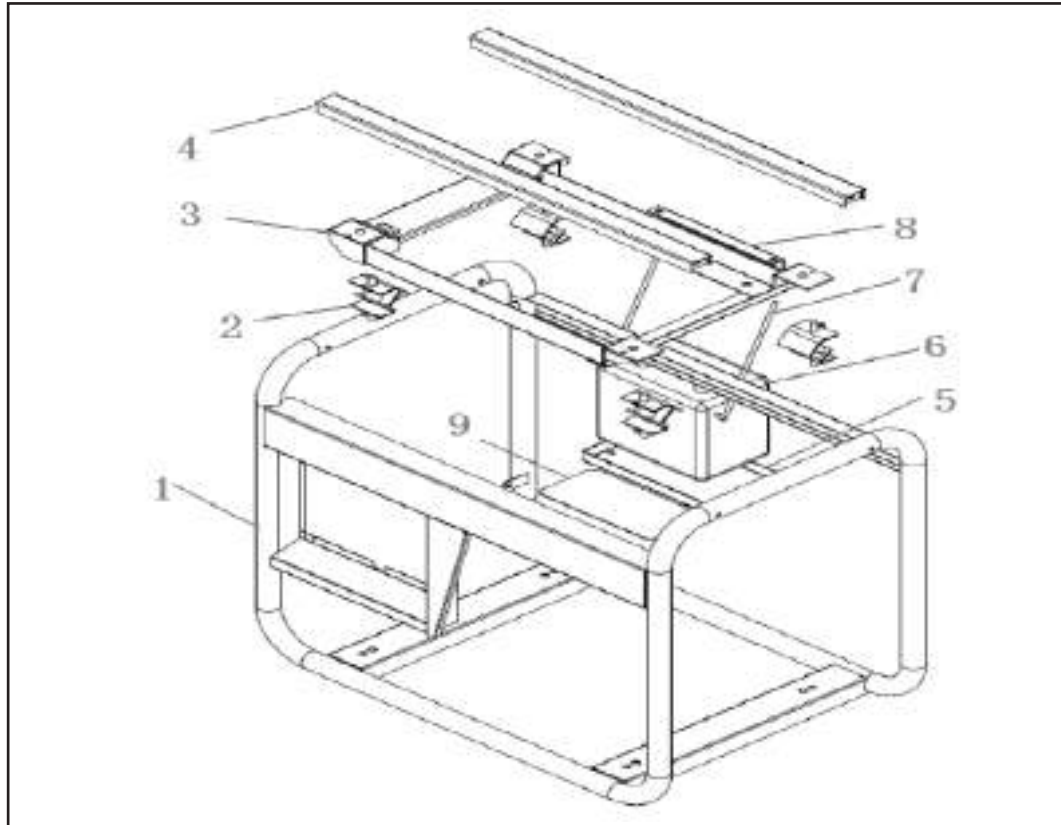

Nº	REF.	DESCRIPCIÓN (ES)	DESCRIPTION (EN)
1	SP-D400-T01	CHASIS MODELO ABIERTO (LE / LE-3)	OPEN FRAME SHAFT(LE/LE-3)
1-1	SP-D400-T01-1	CHASIS MODELO ABIERTO (LE / LE-3)	OPEN FRAME SHAFT(LE/LE-3)
2	SP-D400-T02	SILENT BLOCK (LE / LE-3)	RUBBER ABSORBER(LE/LE-3)
3	SP-D400-T03	BASE SOPORTE DE MOTOR (LE / LE-3)	ENGINE SUPPORT (LE/LE-3)
4	SP-D400-T04	BARRAS PROTECCION (LE / LE-3)	PROTECTION ROD(LE/LE-3)
4-1	SP-D400-T04-1	BARRAS PROTECCION (LE / LE-3)	PROTECTION ROD(LE/LE-3)
5	SP-D400-T05	EL SOPORTE DE BATERIA (LE / LE-3)	BATTERY SUPPORT(LE/LE-3)
7	SP-D400-T07	VARILLA DE SUJECION DE LA BATERÍA (LE/E-3)	BATTERY FASTENING ROD(LE/LE-3)
8	SP-D400-T08	DE SUJECION DE LA BATERIA PLANA (LE/E-3)	BATTERY FASTENING PLATE (LE/LE-3)
9	SP-D400-T09	BASE DE CAUCHO PARA BATERIA (LE / LE-3)	BATTERY RUBBER BASE PLATE(LE/LE-3)
10	SP-D400-T10	BARRA LATERAL PROTECCION	SIDE PROTECTION BAR
11	SP-D400-T11	TAPA ESCAPE	MUFFLER COVER
12	SP-D400-T12	TAPA LATERAL ESCAPE	MUFFLER SIDE COVER



SP-D400-T02



SP-D400-T10



SP-D400-T11



SP-D400-T12



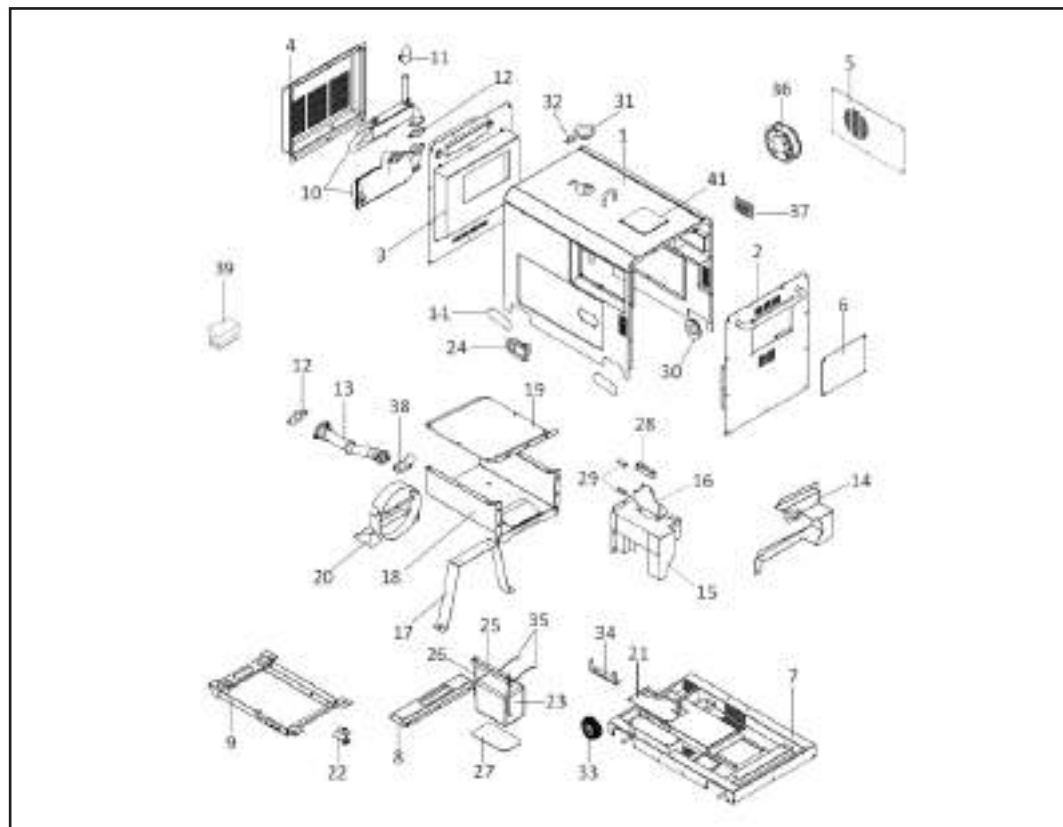

SP-D400-U01-1



SP-D400-U04



SP-D400-U04-1

Nº	REF.	DESCRIPCIÓN (ES)	DESCRIPTION (EN)
1	SP-D400-U01	CARCASA CARROCERIA SE	CANOPY UPPER COVER
1-1	SP-D400-U01-1	TAPA PROTECTOR RUEDAS	WHEEL COVER
1-2	SP-D400-U01-LRS	CARCASA CARROCERIA DG8000SE-LRS	CANOPY UPPER COVER LRS
2	SP-D400-U02	TAPA DERECHA	RIGHT COVER
3	SP-D400-U03	TAPA IZQUIERDA	LEFT COVER
4	SP-D400-U04	TAPA SILENCIADOR ESCAPE SE	MUFFLER COVER
4-1	SP-D400-U04-1	TAPA SILENCIADOR ESCAPE SE	MUFFLER COVER
5	SP-D400-U05	TAPA LATERAL DE ACCESO	REAL DOOR
5-1	SP-D450-U05-1	TAPA LATERAL DE ACCESO CON REJILLA PARA VENTILAR	REAL DOOR (WITH FAN HOLE)
6	SP-D400-U06	TAPA ACCESO FILTRO AIRE	AIR FILTER DOOR
7	SP-D400-U07	BASE CARROCERIA SE	BASE CHASSIS
8	SP-D400-U08	SOPORTE PARTE TRASERA ALTERNADOR	BASE CHASSIS REAL COVER
9	SP-D400-U09	BASE SOPORTE MOTOR	ENGINE SUPPORT
10	SP-D400-U10	SILENCIADOR ESCAPE COMPLETO SE	MUFFLER ASSY
10-1	SP-D500-U10-1	SILENCIADOR ESCAPE COMPLETO SE	MUFFLER ASSY
11	SP-D400-U11	SALIDA ESCAPE DIRECCIONAL	MUFFLER END PIPE
12	SP-D400-U12	JUNTA SILENCIADORES ESCAPE	MUFFLER GASKET
12-1	SP-D500-U12-1	JUNTA SILENCIADORES ESCAPE	MUFFLER GASKET
13	SP-D400-U13	TOBERA FLEXIBLE ESCAPE	BELLOWS
13-1	SP-D500-U13-1	TOBERA FLEXIBLE ESCAPE	BELLOWS
14	SP-D400-U14	PLANCHAS INTERNAS 1	INSIDE PART 1
14-1	SP-D500-U14-1	PLANCHAS INTERNAS 1-1	INSIDE PART 1-1
15	SP-D400-U15	PLANCHAS INTERNAS 2	INSIDE PART 2
15-1	SP-D500-U15-1	PLANCHAS INTERNAS 2-1	INSIDE PART 2-1
16	SP-D400-U16	SOPORTE MOTOR	INSIDE PART 3
17	SP-D400-U17	PLANCHAS INTERNAS 4	INSIDE PART 4
18	SP-D400-U18	PLANCHAS INTERNAS 5	INSIDE PART 5
19	SP-D400-U19	PLANCHAS INTERNAS 6	INSIDE PART 6
20	SP-D400-U20	PLANCHAS INTERNAS 7	INSIDE PART 7
20-1	SP-D400-U20-1	PLANCHAS INTERNAS 7-1	INSIDE PART 7-1
20-2	SP-D400-U20-2	PLANCHAS INTERNAS 7-2	INSIDE PART 7-2
20-3	SP-D400-U20-3	PLANCHAS INTERNAS 7-3	INSIDE PART 7-3
21	SP-D400-U21	BASE METALICA BATERIA 2 ALTURAS	INSIDE PART 8
21-1	SP-D400-U21-1	BASE METALICA BATERIA 1 ALTURA	INSIDE PART 8-1
22	SP-D400-U22	SILENT BLOCKS	RUBBER ABSORBER
23	SP-BAT-36	BATERIA 125x190x160	BATTERY 125x190x160
23-1	SP-BAT-36AH-12V	BATERIA 120x178x200	BATTERY 120x178x200
24	SP-D400-U24	MANETA PUERTA ACCESO	FRONT DOOR HANDLE
25	SP-D400-U25	FIJACION BATERIA	BATTERY FASTENING PLATE
26	SP-D400-U26	JUEGO VARILLAS FIJACION BATERIA 18.5CM	BATTERY FASTENING ROD 18.5CM
26-1	SP-D400-U26-1	JUEGO VARILLAS FIJACION BATERIA 20CM	BATTERY FASTENING ROD 20CM
26-2	SP-D400-U26-2	JUEGO VARILLAS FIJACION BATERIA 22CM	BATTERY FASTENING ROD 22CM

FAST MOVING PARTS

RECOMMENDED PARTS

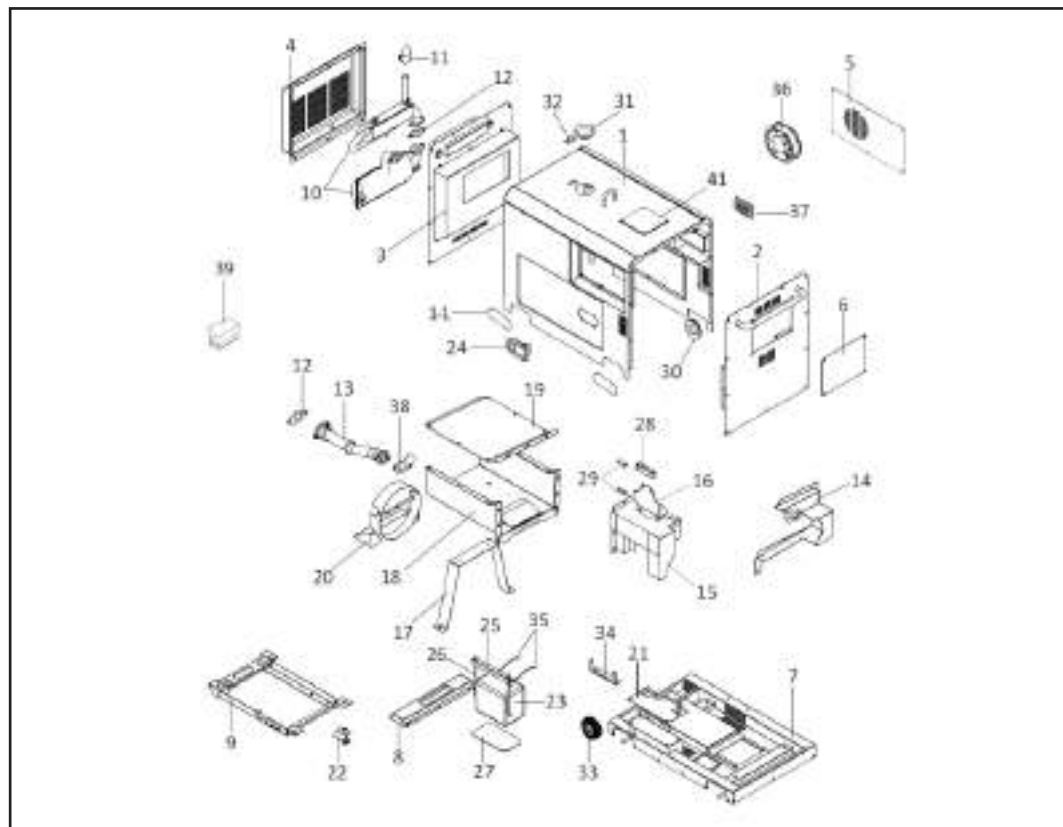

Nº	REF.	DESCRIPCIÓN (ES)	DESCRIPTION (EN)
27	SP-D400-U27	CAUCHO BASE BATERIA	BATTERY RUBBER BASE PLATER
28	SP-D400-U28	GOMA ANTI VIBRACION SUPERIOR MOTOR	ENGINE SILENT-BLOCK
29	SP-D400-U29	FIJADOR TUBO PRESION	HIGH PRESSURE PIPE CLIP
30	SP-D400-U30	GOMA CAJA FILTRO AIRE	RUBBER ROUND COVER FOR AIR INLET PIPE
31	SP-D400-U31	GOMA BOCA DEPOSITO	RUBBER ROUND COVER FOR FUEL TANK
32	SP-D400-U32	VISOR EXTERNO NIVEL COMBUSTIBLE	FUEL TANK INDICATOR DOOR
33	SP-D400-U33	RUEDAS MODELO SE	4 INCH WHEEL
34	SP-D400-U34	SOPORTE AVR	AVR SUPPORT
35	SP-D400-U35	JUEGO CABLES BATERIA	BATTERY CABLE (BOTH OF RED AND BLACK)
36	SP-D400-U36	VENTILADOR 35W 220V	35W ELECTRIC FAN
37	SP-D400-U37	REJILLA ADMISION AIRE	BLIND
38	SP-D400-U38	JUNTA SILENCIADORES ESCAPE	MUFFLER GASKET 2
38-1	SP-D500-U38-1	JUNTA SILENCIADORES ESCAPE	MUFFLER GASKET 2
39	SP-D400-U39	CAJA PORTA FUSIBLES	FUSE HOLDER BOX
40	SP-D400-U40	PLACA ACCESO DEPOSITO	TANK ACCESS PLATE
41	SP-D400-U41	TAPA ACCESO DESCOMPRESOR	DECOMPRESSOR ACCESS COVER
42	SP-D500-U42	SILENCIADOR ESCAPE COMPLETO	MUFFLER ASSY
42-1	SP-D500-U42-1	SILENCIADOR ESCAPE COMPLETO	MUFFLER ASSY
43	SP-D400-U43	CATALIZADOR	CATALYST
43-1	SP-D500-U43	CATALIZADOR D500	CATALYST D500



SP-D400-U33-1



SP-D500-U42



SP-D500-U42-1



SP-D400-U33



SP-D400-U36



SP-D400-U39



SP-D400-U40



SP-D400-U43

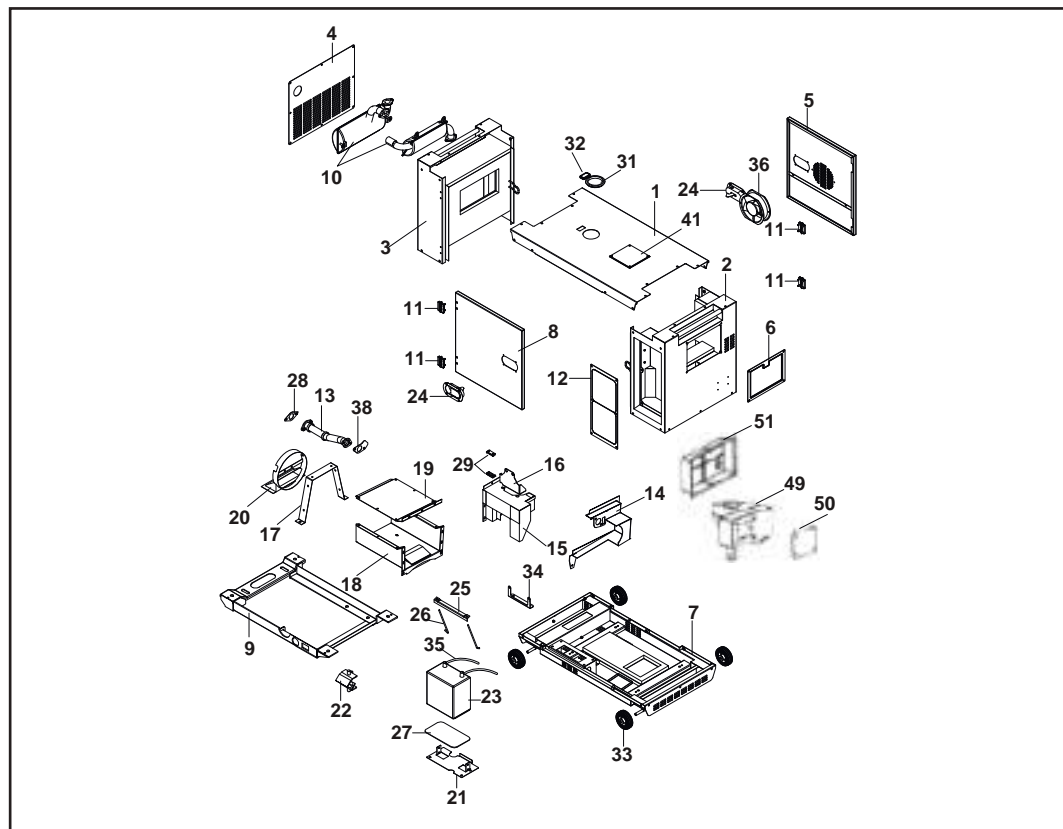

SP-D400-W04



SP-D400-W04-1



SP-D400-U21

Nº	REF.	DESCRIPCIÓN (ES)	DESCRIPTION (EN)
1	SP-D400-W01	TECHO CARROCERIA	ROOF
2	SP-D400-W02	TAPA DERECHA	RIGHT COVER
3	SP-D400-W03	TAPA IZQUIERDA	LEFT COVER
4	SP-D400-W04	TAPA SILENCIADOR ESCAPE	MUFFLER COVER
4-1	SP-D400-W04-1	TAPA SILENCIADOR ESCAPE	MUFFLER COVER
5	SP-D400-W05	TAPA LATERAL DE ACCESO	REAL DOOR
5-1	SP-D450-W05-1	TAPA LATERAL DE ACCESO REJILLA VENTILADOR	REAL DOOR (WITH FAN HOLE)
6	SP-D400-W06	TAPA ACCESO FILTRO AIRE	AIR FILTER DOOR
7	SP-D400-W07	BASE CARROCERIA SE	BASE CHASSIS
8	SP-D400-W08	PUERTA MANTENIMIENTO 8600	MAINTENANCE DOOR 8600
9	SP-D400-W09	BASE SOPORTE MOTOR	ENGINE SUPPORT
10	SP-D400-W10	SILENCIADOR ESCAPE COMPLETO SE	MUFFLER ASSY
10-1	SP-D500-W10-1	SILENCIADOR ESCAPE COMPLETO SE	MUFFLER ASSY
11	SP-D400-W11	BISAGRA	HINGE
12	SP-D400-W12	PANEL DE CONTROL (MONOFASICO)	CONTROL PANEL (SINGLE PHASE)
12-1	SP-D500-W12-1	PANEL DE CONTROL (TRIFASICO)	CONTROL PANEL (THREE PHASE)
12-2	SP-D500-W12-2	PANEL DE CONTROL (FULL POWER)	CONTROL PANEL (FULL POWER)
13	SP-D400-U13	TOBERA FLEXIBLE ESCAPE	BELLOWS
13-1	SP-D500-U13-1	TOBERA FLEXIBLE ESCAPE	BELLOWS
14	SP-D400-U14	PLANCHAS INTERNAS 1	INSIDE PART 1
14-1	SP-D500-U14-1	PLANCHAS INTERNAS 1-1	INSIDE PART 1
15	SP-D400-U15	PLANCHAS INTERNAS 2	INSIDE PART 2
15-1	SP-D500-U15-1	PLANCHAS INTERNAS 2-1	INSIDE PART 2
16	SP-D400-U16	SOPORTE MOTOR	INSIDE PART 3
17	SP-D400-U17	PLANCHAS INTERNAS 4	INSIDE PART 4
18	SP-D400-U18	PLANCHAS INTERNAS 5	INSIDE PART 5
19	SP-D400-U19	PLANCHAS INTERNAS 6	INSIDE PART 6
20	SP-D400-U20	PLANCHAS INTERNAS 7	INSIDE PART 7
20-1	SP-D400-U20-1	PLANCHAS INTERNAS 7-1	INSIDE PART 7-1
20-2	SP-D400-U20-2	PLANCHAS INTERNAS 7-2	INSIDE PART 7-2
20-3	SP-D400-U20-3	PLANCHAS INTERNAS 7-3	INSIDE PART 7-3
21	SP-D400-U21	BASE METALICA BATERIA 2 ALTURAS	INSIDE PART 8
21-1	SP-D400-U21-1	BASE METALICA BATERIA 1 ALTURA	INSIDE PART 8-1
22	SP-D400-U22	SILENT BLOCKS	RUBBER ABSORBER
23	SP-BAT-36	BATERIA 125x190x160	BATTERY 125x190x160
23-1	SP-BAT-36AH-12V	BATERIA 120x178x200	BATTERY 120x178x200
24	SP-D400-U24	MANETA PUERTA ACCESO	FRONT DOOR HANDLE
25	SP-D400-U25	FIJACION BATERIA	BATTERY FASTENING PLATE
26	SP-D400-U26	JUEGO VARILLAS FIJACION BATERIA 18.5CM	BATTERY FASTENING ROD 18.5CM
26-1	SP-D400-U26-1	JUEGO VARILLAS FIJACION BATERIA 20CM	BATTERY FASTENING ROD 20CM

FAST MOVING PARTS

RECOMMENDED PARTS

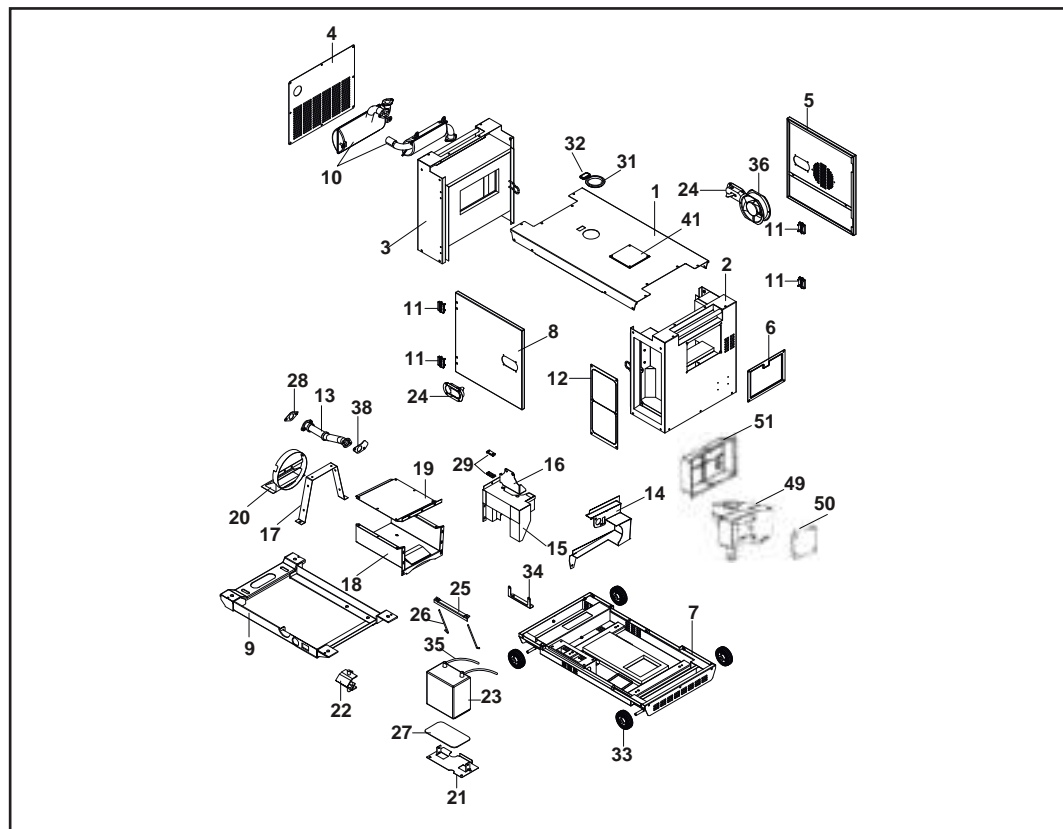

Nº	REF.	DESCRIPCIÓN (ES)	DESCRIPTION (EN)
27	SP-D400-U27	CAUCHO BASE BATERIA	BATTERY RUBBER BASE PLATER
28	SP-D400-U12	JUNTA SILENCIADORES ESCAPE	MUFFLER GASKET
28-1	SP-D500-U12-1	JUNTA SILENCIADORES ESCAPE	MUFFLER GASKET
29	SP-D400-U29	FIJADOR TUBO PRESION	HIGH PRESSURE PIPE CLIP
30	SP-D400-U30	GOMA CAJA FILTRO AIRE	RUBBER ROUND COVER FOR AIR INLET PIPE
31	SP-D400-U31	GOMA BOCA DEPOSITO	RUBBER ROUND COVER FOR FUEL TANK
32	SP-D400-U32	VISOR EXTERNO NIVEL COMBUSTIBLE	FUEL TANK INDICATOR DOOR
33	SP-D400-U33	RUEDAS MODELO SE	4 INCH WHEEL
33-1	SP-D400-U33-1	RUEDAS MODELO SE	4 INCH WHEEL
34	SP-D400-U34	SOPORTE AVR	AVR SUPPORT
35	SP-D400-U35	JUEGO CABLES BATERIA	BATTERY CABLE (BOTH OF RED AND BLACK)
36	SP-D400-U36	VENTILADOR 35W 220V	35W ELECTRIC FAN
38	SP-D400-U38	JUNTA SILENCIADORES ESCAPE	MUFFLER GASKET 2
38-1	SP-D500-U38-1	JUNTA SILENCIADORES ESCAPE	MUFFLER GASKET 2
40	SP-D400-U40	PLACA ACCESO DEPOSITO	TANK ACCESS PLATE
41	SP-D400-U41	TAPA ACCESO DESCOMPRESOR	DECOMPRESSOR ACCESS COVER
42	SP-D400-U42	SILENCIADOR ESCPAE COMPLETO	MUFFLER ASSY
42-1	SP-D500-U42-1	SILENCIADOR ESCAPE COMPLETO	MUFFLER ASSY
43	SP-D400-U43	CATALIZADOR	CATALYST
43-1	SP-D500-U43	CATALIZADOR	CATALYST
45	SP-D400-U45	PLANCHA SUPERIOR ESCAPE (38X12)	UPPER MUFFLER PLATE (38X12)
48	SP-D400-U48	KIT SILENCIADOR ESCAPE + TOBERA FLEXIBLE ENTRADA D400 SALIDA D500	MUFFLER ASSY + BELLOW KIT INPUT D400 OUTPUT D500
48-1	SP-D500-U48	KIT SILENCIADOR ESCAPE + TOBERA FLEXIBLE ENTRADA Y SALIDA D500	MUFFLER ASSY + BELLOW KIT INPUT & OUTPUT D500
49	SP-D500-U49	CODO ADAPTADOR FILTRO AIRE	AIR FILTER ADAPTER ELBOW
50	SP-D500-U50	PLACA CUBIERTA ADAPTADOR FILTRO AIRE	COVER PLATE OF AIR FILTER ADAPTER
51	SP-D500-U51	CUBIERTA POSTERIOR PANEL	PANEL BACK COVER



SP-D400-U33-1



SP-D500-U42-1



SP-D400-U33



SP-D400-U36



SP-D400-U39



SP-D400-U40



SP-D400-U43



SP-D400-U45

FAST MOVING PARTS

RECOMMENDED PARTS

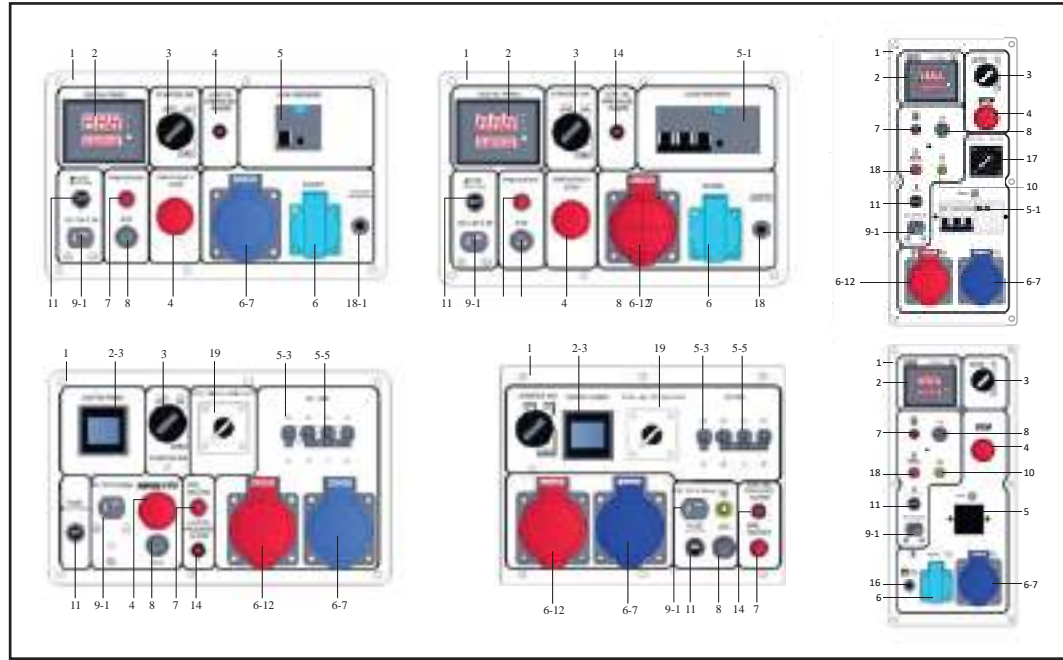

FAST MOVING PARTS

RECOMMENDED PARTS

Nº	REF.	DESCRIPCIÓN (ES)	DESCRIPTION (EN)
1	SP-PC-PANEL-D400LE	PANEL DE CONTROL COMPLETO D400LE	CONTROL PANEL ASSY D400LE
1-1	SP-PC-PANEL-D400SE	PANEL DE CONTROL COMPLETO D400SE	CONTROL PANEL ASSY D400SE
1-2	SP-PC-PANEL-D400LE-3	PANEL DE CONTROL COMPLETO D400LE-3	CONTROL PANEL ASSY D400LE-3
1-3	SP-PC-PANEL-D400SE-3	PANEL DE CONTROL COMPLETO D400SE-3	CONTROL PANEL ASSY D400SE-3
1-4	SP-PC-PANEL-D400LET	PANEL DE CONTROL COMPLETO D400LET	CONTROL PANEL ASSY D400LET
1-5	SP-PC-PANEL-D400SET	PANEL DE CONTROL COMPLETO D400SET	CONTROL PANEL ASSY D400SET
1-6	SP-PC-PANEL-D450LE	PANEL DE CONTROL COMPLETO D450LE	CONTROL PANEL ASSY D450LE
1-7	SP-PC-PANEL-D450SE	PANEL DE CONTROL COMPLETO D450SE	CONTROL PANEL ASSY D450SE
1-8	SP-PC-PANEL-D450LE-3	PANEL DE CONTROL COMPLETO D450LE-3	CONTROL PANEL ASSY D450LE-3
1-9	SP-PC-PANEL-D450SE-3	PANEL DE CONTROL COMPLETO D450SE-3	CONTROL PANEL ASSY D450SE-3
1-10	SP-PC-PANEL-D450LET	PANEL DE CONTROL COMPLETO D450LET	CONTROL PANEL ASSY D450LET
1-11	SP-PC-PANEL-D450SET	PANEL DE CONTROL COMPLETO D450SET	CONTROL PANEL ASSY D450SET
1-12	SP-PC-PANEL-D500LE	PANEL DE CONTROL COMPLETO D500LE	CONTROL PANEL ASSY D500LE
1-13	SP-PC-PANEL-D500SE	PANEL DE CONTROL COMPLETO D500SE	CONTROL PANEL ASSY D500SE
1-14	SP-PC-PANEL-D500LE-3	PANEL DE CONTROL COMPLETO D500LE-3	CONTROL PANEL ASSY D500LE-3
1-15	SP-PC-PANEL-D500SE-3	PANEL DE CONTROL COMPLETO D500SE-3	CONTROL PANEL ASSY D500SE-3
1-16	SP-PC-PANEL-D500LET	PANEL DE CONTROL COMPLETO D500LET	CONTROL PANEL ASSY D500LET
1-17	SP-PC-PANEL-D500SET	PANEL DE CONTROL COMPLETO D500SET	CONTROL PANEL ASSY D500SET
1-18	SP-PC-PANEL-8600SE	PANEL DE CONTROL COMPLETO 8600SE	CONTROL PANEL ASSY 8600SE
1-19	SP-PC-PANEL-8600SET	PANEL DE CONTROL COMPLETO 8600SET	CONTROL PANEL ASSY 8600SET
2	SP-PC-LED5-1PH	LED5 DISPLAY (LE/SE) (MONOFASICO)	LED5 DISPLAY (LE/SE) (SINGLE PHASE)
2-1	SP-PC-LED5-3PH	LED5 DISPLAY (LE-3/SE-3) (3 PHASE)	LED5 DISPLAY (LE-3/SE-3) (3 PHASE)
2-2	SP-PC-LED5-FULL	LED5 DISPALY (LET/SET) (FULL POWER)	LED5 DISPLAY (LET/SET) (FULL POWER)
2-3	SP-PC-LED3-1PH	LED3 DISPLAY (LE/SE) (MONOFASICO)	LED3 DISPLAY (LE/SE) (SINGLE PHASE)
2-4	SP-PC-LED3-3PH	LED3 DISPLAY (LE-3/SE-3) (3 PHASE)	LED3 DISPLAY (LE-3/SE-3) (3 PHASE)

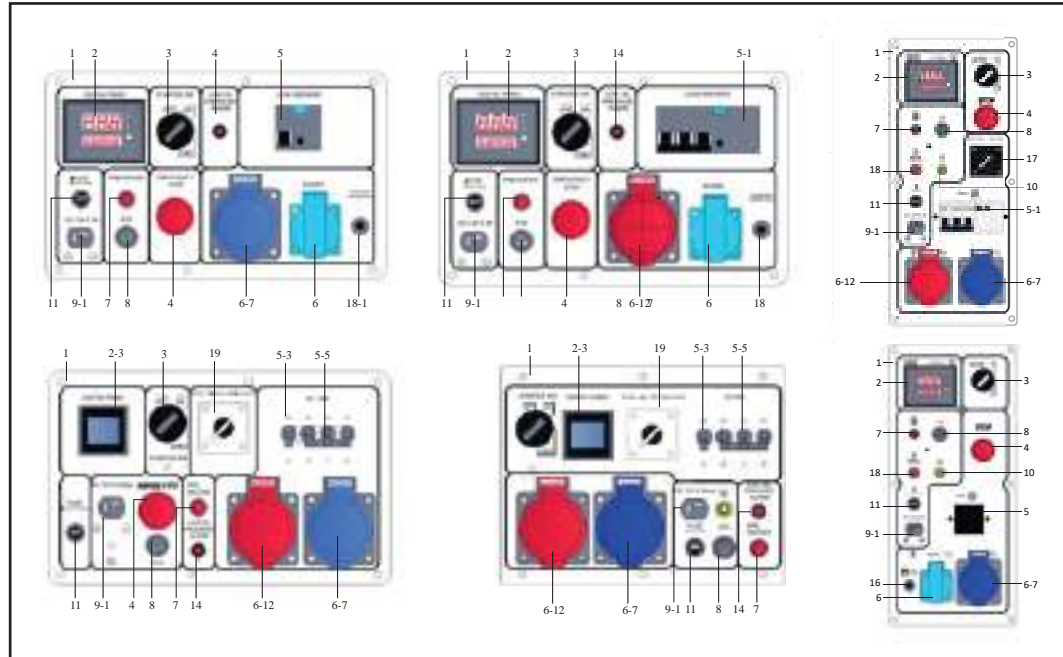

SP-PC-INT-1P

SP-PC-INT-3P

SP-PC-BASE-SCH-16A-IP44

SP-PC-BASE-SCH-32A-IP44

SP-PC-BASE-SCH-16A-5P

Nº	REF.	DESCRIPCIÓN (ES)	DESCRIPTION (EN)
2-5	SP-PC-LED3-FULL	LED3 DISPALY (LET/SET) (FULL POWER)	LED3 DISPLAY (LET/SET) (FULL POWER)
2-6	SP-PC-LED	DISPLAY LED (LE/SE) (MONOFASICO)	DISPLAY LED (LE/SE) (SINGLE PHASE)
2-7	SP-PC-VOLT-1PH	VOLTIMETRO ANALOGICO (MONOFASICO)	ANALOGIC VOLTMETER (SINGLE PHASE)
2-8	SP-PC-VOLT-1PH	VOLTIMETRO ANALOGICO (TRIFASICO)	ANALOGIC VOLTMETER (THREE PHASE)
2-9	SP-PC-LED-1	DISPLAY LED TIPO 1	LED DISPLAY TYPE 1
2-10	SP-PC-LED-2	DISPLAY LED TIPO 2	LED DISPLAY TYPE 2
2-11	SP-PC-LED-6	LED 6 DISPLAY	LED 6 DISPLAY
2-12	SP-PC-DC30D	PANTALLA DIGITAL DC30D	DIGITAL DISPLAY DC30D
3	SP-PC-STARTER-D	BOMBIN DE ARRANQUE DIESEL	KEY STARTER DIESEL
4	SP-PC-STOP	PARO DE EMRGENCIA	E-STOP BUTTON
5	SP-PC-DELIXI-1-C6	DIFERENCIAL DELIXI 1P 6AH	LEAKAGE BREAKER 1P 6A
5-1	SP-PC-DELIXI-1-C10	DIFERENCIAL DELIXI 1P 10AH	LEAKAGE BREAKER 1P 10A
5-2	SP-PC-DELIXI-2-C6	DIFERENCIAL DELIXI 2P 6AH	LEAKAGE BREAKER 2P 6A
5-3	SP-PC-DELIXI-2-C10	DIFERENCIAL DELIXI 2P 10AH	LEAKAGE BREAKER 2P 10A
5-4	SP-PC-DELIXI-2-C16	DIFERENCIAL DELIXI 2P 16AH	LEAKAGE BREAKER 2P 16A
5-5	SP-PC-DELIXI-2-C25	DIFERENCIAL DELIXI 2P 25AH	LEAKAGE BREAKER 2P 25A
5-6	SP-PC-DELIXI-2-C32	DIFERENCIAL DELIXI 2P 32AH	LEAKAGE BREAKER 2P 32A
5-7	SP-PC-DELIXI-4-C10	DIFERENCIAL DELIXI 4P 10AH	LEAKAGE BREAKER 4P 10A
5-8	SP-PC-DELIXI-4-C16	DIFERENCIAL DELIXI 4P 16AH	LEAKAGE BREAKER 4P 16A
5-9	SP-PC-DELIXI-4-C20	DIFERENCIAL DELIXI 4P 20AH	LEAKAGE BREAKER 4P 20A
5-10	SP-PC-DELIXI-4-C25	DIFERENCIAL DELIXI 4P 25AH	LEAKAGE BREAKER 4P 25A
5-11	SP-PC-DELIXI-4-C32	DIFERENCIAL DELIXI 4P 32AH	LEAKAGE BREAKER 4P 32A
5-12	SP-PC-INT-1P-8A	DIFERENCIAL NEGRO 1P 8AH	BLACK BREAKER 1P 8A
5-13	SP-PC-INT-1P-12A	DIFERENCIAL NEGRO 1P 12AH	BLACK BREAKER 1P 12A
5-14	SP-PC-INT-1P-16,7A	DIFERENCIAL NEGRO 1P 16,7AH	BLACK BREAKER 1P 16.7A
5-15	SP-PC-INT-1P-20A	DIFERENCIAL NEGRO 1P 20AH	BLACK BREAKER 1P 20A
5-16	SP-PC-INT-1P-26A	DIFERENCIAL NEGRO 1P 26AH	BLACK BREAKER 1P 26A
5-17	SP-PC-INT-1P-30A	DIFERENCIAL NEGRO 1P 30AH	BLACK BREAKER 1P 30A
5-18	SP-PC-INT-3P-6A	DIFERENCIAL NEGRO 3P 6AH	BLACK BREAKER 3P 6A
5-19	SP-PC-INT-3P-7,8A	DIFERENCIAL NEGRO 3P 7,8AH	BLACK BREAKER 3P 7.8A
5-20	SP-PC-INT-3P-10A	DIFERENCIAL NEGRO 3P 10AH	BLACK BREAKER 3P 10A
5-21	SP-PC-INT-3P-16A	DIFERENCIAL NEGRO 3P 16AH	BLACK BREAKER 3P 16A
5-22	SP-PC-INT-3P-25A	DIFERENCIAL NEGRO 3P 25AH	BLACK BREAKER 3P 25A
6	SP-PC-BASE-SCH-16A-IP54	BASE SCHUKO 16A 220V 2P	EUROPE SOCKET 16A SCHUKO 2P 220V
6-1	SP-PC-BASE-SCH-16A-IP44	BASE SCHUKO 16A 220V 3P	EUROPE SOCKET 16A SCHUKO 3P 220V
6-2	SP-PC-BASE-SCH-32A-IP44	BASE SCHUKO 32A 220V 3P	EUROPE SOCKET 32A PCE 3P 220V
6-3	SP-PC-BASE-SCH-16A-5P	BASE SCHUKO 16A 380V 5P	EUROPE SOCKET 16A PCE 5P 380V

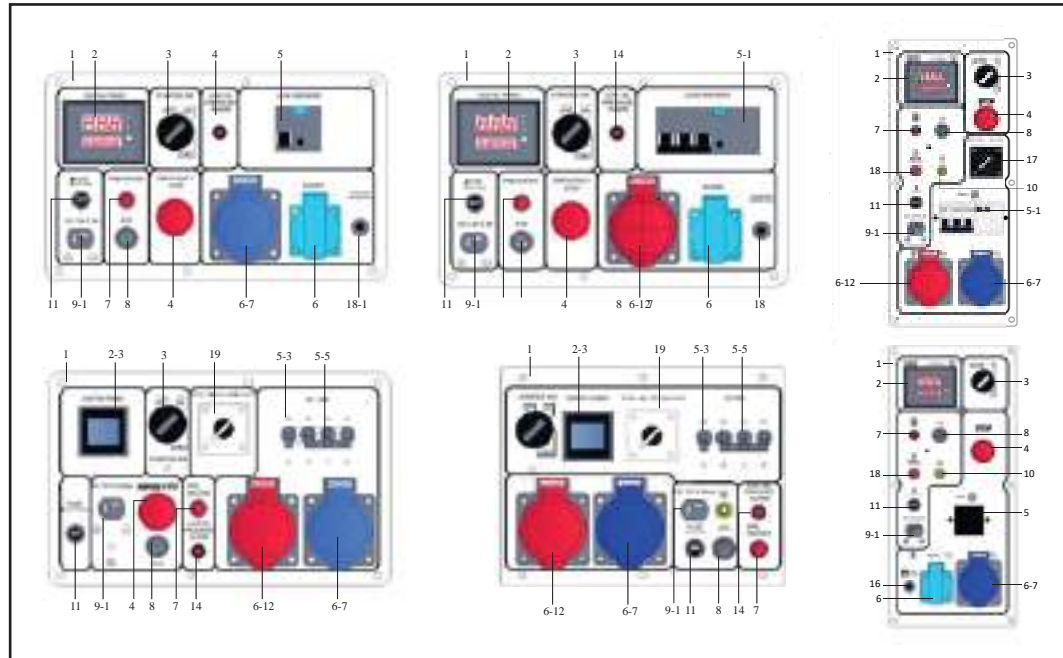

Nº	REF.	DESCRIPCIÓN (ES)	DESCRIPTION (EN)
6-4	SP-PC-BASE-SCH-32A-IP67	BASE SCHUKO 32A 380V 5P	EUROPE SOCKET 32A PCE 5P 380V
7	SP-PC-PRE-HEATER	PULSADOR PRECALENTADOR	AIR PRE-HEATER BUTTON
8	SP-PC-ATS-3	CONECTOR ATS PANEL	ATS SOCKET
9	SP-PC-CON-12V	TERMINALES 12V/DC (ROJO Y NEGRO)	12V/DC TERMINALS (RED AND BLACK TERMINALS)
9-1	SP-PC-CON-12V-T	CONECTOR TIPO T 12V/DC	T-TYPE 12V/DC CONNECTOR
9-2	SP-PC-CON-12V-V	CONECTOR TIPO V 12V/DC	V-TYPE 12V/DC CONNECTOR
10	SP-PC-CON-EARTH	TUERCA DE TIERRAD	GROUNDING NUT
11	SP-ATS-FUSE-BOX	PORTAFUSIBLES	FUSE HOLDER
11-1	SP-PC-FUSE-10A	FUSIBLE 10A	FUSE 10A
12	SP-PC-MODUL-ATS	MODULO ATS	ATS MODULE
12-1	SP-PC-MODUL-ATS-GRIS	MODULO ATS GRIS	ATS MODULE
12-2	AC-MANDO DIESEL	MODULO ATS CON MANDO DISTANCIA DIESEL	ATS + REMOTE CONTROL MODULE
12-3	SP-PC-MODUL-ATS-22	MODULO ATS DIESEL 2022	ATS DIESEL MODULE 2022
13	SP-PC-RECTI	RECTIFICADOR 12V MOD.DBPC3510	RECTIFIER 12V MOD.DBPC3510
13-1	SP-PC-RECTI-1	RECTIFICADOR 12V MOD.DBPC2510	RECTIFIER 12V MOD.DBPC2510
13-2	SP-PC-RECTI-2	RECTIFICADOR 12V MOD.KBPC5010	RECTIFIER 12V MOD.KBPC5010
14	SP-PC-OIL-LED	LED ALARMA SENSOR ACEITE	LED OIL DETECTION SENSOR
14-1	SP-PC-PLACA-OIL-5C	PLACA SENSOR ACEITE 5 CABLES	OIL SENSOR PLATE 5 CABLES
14-2	SP-PC-PLACA-OIL-6C	PLACA SENSOR ACEITE 6 CABLES	OIL SENSOR PLATE 6 CABLES
14-3	SP-PC-PLACA	PLACA ELECTRONICA DEL DISPLAY	ELECTRONIC DISPLAY PLATE
14-4	SP-PC-PLACA-D2006	PLACA ELECTRONICA DEL 2006	2006 ELECTRONIC PLATE
14-5	SP-PC-PLACA-DED-DIESEL	PLACA ELECTRONICA DISPLAY DIESEL	DISPLAY PLATE DIESEL
16	SP-PC-HOUR-ANA	CUENTAHORAS ANALOGICO 12V	ANALOGIC HOURS METER 12V
17	SP-PC-SELEC	INTERRUPTOR SELECTOR	SELECTOR SWITCH
18	SP-PC-OVER-8A	PROTECTOR 12V 8A	OVERLOAD PROTECTOR 8A
18-1	SP-PC-OVER-10A	PROTECTOR 12V 10A	OVERLOAD PROTECTOR 10A
18-2	SP-PC-OVER-14A	PROTECTOR 12V 14A	OVERLOAD PROTECTOR 14A
19	SP-PC-SELEC-T	SELECTOR VOLTAJE FUL POWER	SELECTORS SWITCH FULL POWER
20	SP-PC-TOROIDAL-LED6	TOROIDAL PANTALLA LED 6	TOROIDAL LED 6 DISPLAY
21	SP-PC-RESISTENCIA	RESISTENCIA 2,4K (3W)	RESISTANCE 2.4K (3W)
22	SP-PC-JD1914	RELE 12V-40A 5P	RELAY 12V-40A 5P



FAST MOVING PARTS

RECOMMENDED PARTS